

3

Factors and Products

BUILDING ON

- determining factors and multiples of whole numbers to 100
- identifying prime and composite numbers
- determining square roots of rational numbers
- adding and subtracting polynomials
- multiplying and dividing polynomials by monomials

BIG IDEAS

- Arithmetic operations on polynomials are based on the arithmetic operations on integers, and have similar properties.
- Multiplying and factoring are inverse processes, and a rectangle diagram can be used to represent them.

NEW VOCABULARY

prime factorization
greatest common factor
least common multiple
perfect cube, cube root
radicand, radical, index
factoring by decomposition
perfect square trinomial
difference of squares



AERIAL PHOTO OF MANITOBA

The Dominion Land Survey divides much of western Canada into 1-mile square sections. This photo shows canola fields around Shoal Lake, located in western Manitoba.



3.1 Factors and Multiples of Whole Numbers

LESSON FOCUS

Determine prime factors, greatest common factors, and least common multiples of whole numbers.

The origins of these belts are unknown. They are on display in the MacBride museum in Whitehorse, Yukon.



Make Connections

In the belts above, the patterns are 12 beads long and 40 beads long. How many beads long must a belt be for it to be created using either pattern?

Construct Understanding

TRY THIS

Work with a partner.

- List some powers of 2. Make another list of powers of 3. Pick a number from each list and multiply them to create a different number. What are the factors of this number? What are some multiples of this number?
- Compare your number to your partner's number. Which factors do the two numbers have in common? Which factor is the greatest?
- What are some multiples the two numbers have in common? Which multiple is the least?
- How can you use the product of powers from Step A to determine the greatest factor and the least multiple that the numbers have in common?

When a factor of a number has exactly two divisors, 1 and itself, the factor is a *prime factor*. For example, the factors of 12 are 1, 2, 3, 4, 6, and 12. The prime factors of 12 are 2 and 3. To determine the **prime factorization** of 12, write 12 as a product of its prime factors: $2 \times 2 \times 3$, or $2^2 \times 3$

To avoid confusing the multiplication symbol with the variable x , we use a dot to represent the multiplication operation: $12 = 2 \cdot 2 \cdot 3$, or $2^2 \cdot 3$

The first 10 prime numbers are: 2, 3, 5, 7, 11, 13, 17, 19, 23, 29
Natural numbers greater than 1 that are not prime are *composite*.

The **prime factorization** of a natural number is the number written as a product of its prime factors.

Every composite number can be expressed as a product of prime factors.

Example 1 Determining the Prime Factors of a Whole Number

Write the prime factorization of 3300.

SOLUTIONS

Method 1

Draw a factor tree.

Write 3300 as a product of 2 factors.

Both 33 and 100 are composite numbers, so we can factor again.

Both 3 and 11 are prime factors, but 4 and 25 can be factored

further.

The prime factors of 3300 are 2, 3, 5, and 11.

The prime factorization of 3300 is: $2 \cdot 2 \cdot 3 \cdot 5 \cdot 5 \cdot 11$,
or $2^2 \cdot 3 \cdot 5^2 \cdot 11$

Method 2

Use repeated division by prime factors.

Begin by dividing 3300 by the least prime factor, which is 2.

Divide by this prime factor until it is no longer a factor.

Continue to divide each quotient by a prime factor until the quotient is 1.

$$3300 \div 2 = 1650$$

$$1650 \div 2 = 825$$

$$825 \div 3 = 275$$

$$275 \div 5 = 55$$

$$55 \div 5 = 11$$

$$11 \div 11 = 1$$

The prime factors of 3300 are 2, 3, 5, and 11.

The prime factorization of 3300 is: $2 \cdot 2 \cdot 3 \cdot 5 \cdot 5 \cdot 11$,
or $2^2 \cdot 3 \cdot 5^2 \cdot 11$

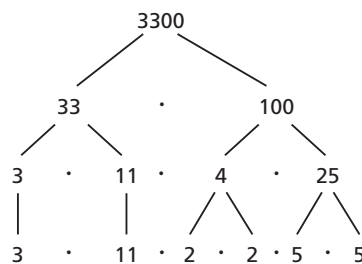

CHECK YOUR UNDERSTANDING

- Write the prime factorization of 2646.

[Answer: $2 \cdot 3^3 \cdot 7^2$]

What other factor trees could you draw?

Could we have divided by the prime factors in a different order? If so, which order do you think is best? Why?

The **greatest common factor** of two or more numbers is the greatest factor the numbers have in common.

For 2 or more natural numbers, we can determine their **greatest common factor**.

Example 2 Determining the Greatest Common Factor

Determine the greatest common factor of 138 and 198.

SOLUTIONS

Method 1

Use division facts to determine all the factors of each number. Record the factors as a “rainbow.”

$$\begin{aligned} 138 \div 1 &= 138 \\ 138 \div 2 &= 69 \\ 138 \div 3 &= 46 \\ 138 \div 6 &= 23 \end{aligned}$$

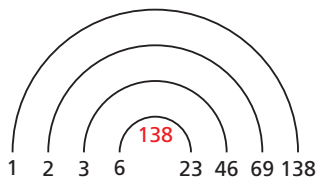

Since 23 is a prime number, there are no more factors of 138.

$$\begin{aligned} 198 \div 1 &= 198 \\ 198 \div 2 &= 99 \\ 198 \div 3 &= 66 \\ 198 \div 6 &= 33 \\ 198 \div 9 &= 22 \\ 198 \div 11 &= 18 \end{aligned}$$

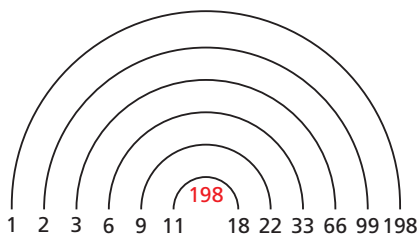

There are no more factors of 198 between 11 and 18.

The common factors of 138 and 198 are: 1, 2, 3, and 6.

So, the greatest common factor is 6.

Method 2

Check to see which factors of 138 are also factors of 198.

Start with the greatest factor.

The factors of 138 are: 1, 2, 3, 6, 23, 46, 69, 138

198 is not divisible by 138, 69, 46, or 23.

198 is divisible by 6: $198 \div 6 = 33$

The greatest common factor is 6.

Method 3

Write the prime factorization of each number.

Highlight the factors that appear in each prime factorization.

$$138 = 2 \cdot 3 \cdot 23$$

$$198 = 2 \cdot 3 \cdot 3 \cdot 11$$

The greatest common factor is $2 \cdot 3$, which is 6.

CHECK YOUR UNDERSTANDING

- Determine the greatest common factor of 126 and 144.

[Answer: 18]

How would you determine the greatest common factor of 3 numbers?

To generate multiples of a number, multiply the number by the natural numbers; that is, 1, 2, 3, 4, 5, and so on. For example, some multiples of 26 are:

$$26 \cdot 1 = 26 \quad 26 \cdot 2 = 52 \quad 26 \cdot 3 = 78 \quad 26 \cdot 4 = 104$$

For 2 or more natural numbers, we can determine their **least common multiple**.

We can determine the least common multiple of 4 and 6 by combining identical copies of each smaller chain to create two chains of equal length.

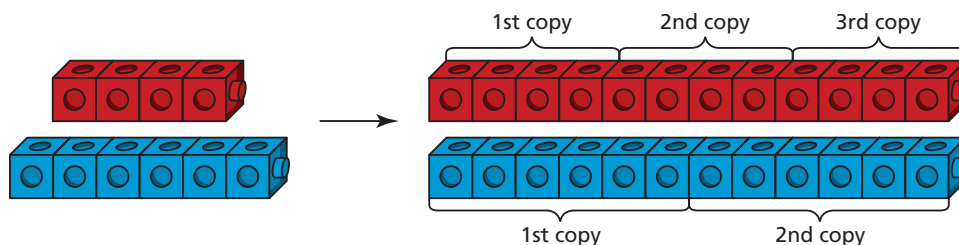

The shortest chain possible is 12 cubes long.
So, the least common multiple of 4 and 6 is 12.

The **least common multiple** of two or more numbers is the least number that is divisible by each number.

Example 3 Determining the Least Common Multiple

Determine the least common multiple of 18, 20, and 30.

SOLUTIONS

Method 1

List the multiples of each number until the same multiple appears in all 3 lists.

Multiples of 18 are: 18, 36, 54, 72, 90, 108, 126, 144, 162, **180**, ...

Multiples of 20 are: 20, 40, 60, 80, 100, 120, 140, 160, **180**, ...

Multiples of 30 are: 30, 60, 90, 120, 150, **180**, ...

The least common multiple of 18, 20, and 30 is 180.

Method 2

Check to see which multiples of 30 are also multiples of 18 and 20.

The multiples of 30 are: 30, 60, 90, 120, 150, 180, ...

18 divides exactly into: 90, **180**, ...

20 divides exactly into: 60, 120, **180**, ...

The least common multiple of 18, 20, and 30 is 180.

(Solution continues.)

CHECK YOUR UNDERSTANDING

- Determine the least common multiple of 28, 42, and 63.

[Answer: 252]

Method 3

Write the prime factorization of each number.

Highlight the greatest power of each prime factor in any list.

$$18 = 2 \cdot 3 \cdot 3 = 2 \cdot 3^2 \quad \text{The greatest power of 3 in any list is } 3^2.$$

$$20 = 2 \cdot 2 \cdot 5 = 2^2 \cdot 5 \quad \text{The greatest power of 2 in any list is } 2^2.$$

$$30 = 2 \cdot 3 \cdot 5 \quad \text{The greatest power of 5 in any list is } 5.$$

The least common multiple is the product of the greatest power of each prime factor:

$$\begin{aligned} 2^2 \cdot 3^2 \cdot 5 &= 4 \cdot 9 \cdot 5 \\ &= 180 \end{aligned}$$

The least common multiple of 18, 20, and 30 is 180.

Are there any pairs of numbers for which the least common multiple and greatest common factor are the same number? Explain.

Example 4

Solving Problems that Involve Greatest Common Factor and Least Common Multiple

- a) What is the side length of the smallest square that could be tiled with rectangles that measure 16 cm by 40 cm? Assume the rectangles cannot be cut. Sketch the square and rectangles.
- b) What is the side length of the largest square that could be used to tile a rectangle that measures 16 cm by 40 cm? Assume that the squares cannot be cut. Sketch the rectangle and squares.

SOLUTION

- a) In the square, arrange all the rectangles with the same orientation.

The shorter side of each rectangle measures 16 cm. So, the side length of the square must be a multiple of 16.

The longer side of each rectangle measures 40 cm. So, the side length of the square must be a multiple of 40.

So, the side length of the square must be a common multiple of 16 and 40.

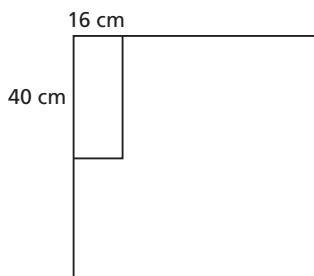

(Solution continues.)

CHECK YOUR UNDERSTANDING

4. a) What is the side length of the smallest square that could be tiled with rectangles that measure 8 in. by 36 in.? Assume the rectangles cannot be cut. Sketch the square and rectangles.
- b) What is the side length of the largest square that could be used to tile a rectangle that measures 8 in. by 36 in.? Assume that the squares cannot be cut. Sketch the rectangle and squares.

[Answers: a) 72 in. b) 4 in.]

The side length of the smallest square will be the least common multiple of 16 and 40.

Write the prime factorization of each number. Highlight the greatest power of each prime factor in either list.

$$16 = 2^4$$

$$40 = 2^3 \cdot 5$$

The least common multiple is:
 $2^4 \cdot 5 = 80$

The side length of the smallest square is 80 cm.

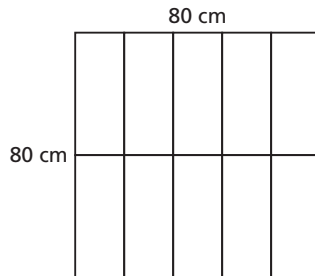

In *Example 4a*, would the answer change if the rectangles could be oriented in any direction? Explain.

- b) The shorter side of the rectangle measures 16 cm. So, the side length of the square must be a factor of 16.

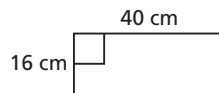

The longer side of the rectangle measures 40 cm. So, the side length of the square must be a factor of 40.

So, the side length of the square must be a common factor of 16 and 40.

The side length of the largest square will be the greatest common factor of 16 and 40.

Write the prime factorization of each number.
 Highlight the prime factors that appear in both lists.

$$16 = 2 \cdot 2 \cdot 2 \cdot 2$$

$$40 = 2 \cdot 2 \cdot 2 \cdot 5$$

The greatest common factor is:
 $2 \cdot 2 \cdot 2 = 8$

The largest square has side length 8 cm.

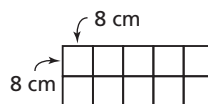

Why is it helpful to write the prime factorization of 16 and 40 as a product of powers in part a and as an expanded product in part b?

Discuss the Ideas

1. What strategies can you use to determine the prime factorization of a whole number?
2. How can you use the prime factorization of a number to determine all the factors of that number?

20. The Dominion Land Survey is used to divide much of western Canada into sections and acres. One acre of land is a rectangle measuring 66 feet by 660 feet.

- A section is a square with side length 1 mile. Do the rectangles for 1 acre fit exactly into a section? Justify your answer.
[1 mile = 5280 feet]
- A quarter section is a square with side length $\frac{1}{2}$ mile. Do the rectangles for 1 acre fit exactly into a quarter section? Justify your answer.
- What is the side length of the smallest square into which the rectangles for 1 acre will fit exactly?

C

- Marcia says that she knows that 61 is a prime number because she tried dividing 61 by all the natural numbers up to and including 7, and none of them was a factor. Do you agree with Marcia? Explain.
- A bar of soap has the shape of a rectangular prism that measures 10 cm by 6 cm by 3 cm. What is the edge length of the smallest cube that could be filled with these soap bars?

Reflect

Describe strategies you would use to determine the least common multiple and the greatest common factor of a set of numbers.



THE WORLD OF MATH

Math Fact: Cryptography

Cryptography is the art of writing or deciphering messages in code. Cryptographers use a key to encode and decode messages. One way to generate a key is to multiply two large prime numbers. This makes it almost impossible to decipher the code without knowing the original numbers that were multiplied to encipher the message.

In 2006, mathematicians announced they had factored a 274-digit number as the product of a 120-digit prime number and a 155-digit prime number.

$$\begin{aligned}
 c_{274} &= \frac{6^{353} - 1}{5} \\
 &= 9736915051844164425659589830765310381017746994454460344424676734039701450849424662984652946941 \\
 &\quad 8789179481605188614420406622642320616708178468189806366368550930451357370697905234613513066631 \\
 &\quad 78231611242601530501649312653193616879609578238789980474856787874287635916569919566643 \\
 &= p_{120} \times p_{155} \\
 &= 1350952613301126518307750496355908073811210311113827323183908467597440721656365429201433517381 \\
 &\quad 98057636666351316191686483 \times 7207443811113019376439358640290253916138908670997078170498495662717 \\
 &\quad 8573407484509481161087627373286704178679466051451768242073072242783688661390273684623521
 \end{aligned}$$

3.2 Perfect Squares, Perfect Cubes, and Their Roots

LESSON FOCUS

Identify perfect squares and perfect cubes, then determine square roots and cube roots.

Kubiks were temporary structures built in Barcelona, Berlin, and Lisbon in 2007.



Make Connections

The edge length of the Rubik's cube is 3 units.

What is the area of one face of the cube? Why is this number a *perfect square*?

What is the volume of the cube? This number is called a **perfect cube**. Why do you think it has this name?



Competitors solve a Rubik's cube in the world championships in Budapest, Hungary, in October 2007.

Construct Understanding

TRY THIS

Work in a group.

You will need: 100 congruent square tiles, 100 linking cubes, grid paper, and isometric dot paper.

- A. Use the tiles to model all the perfect squares from 1 to 100. Sketch each model on grid paper and record the corresponding perfect square.
- B. Use the cubes to model all the perfect cubes from 1 to 100. Sketch each model on isometric dot paper and record the corresponding perfect cube.
- C. Which numbers from 1 to 100 are perfect squares and which are perfect cubes?
- D. Join with another group of students. Take turns to choose a number between 101 and 200. Determine if it is a perfect square or a perfect cube.
- E. Suppose you did not have tiles or cubes available. How could you determine if a given number is a perfect square? How could you determine if a given number is a perfect cube?

Any whole number that can be represented as the area of a square with a whole number side length is a *perfect square*.

The side length of the square is the *square root* of the area of the square.

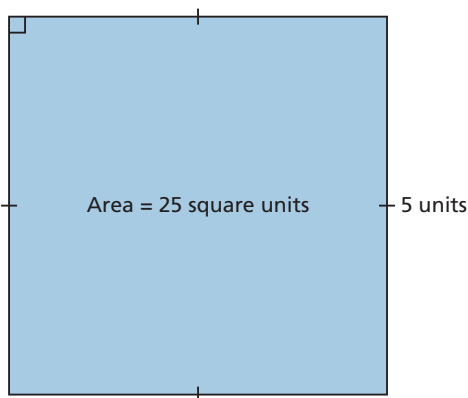

We write: $\sqrt{25} = 5$

25 is a perfect square and 5 is its square root.

The *square root* of a number n , denoted \sqrt{n} , is a positive number whose square is n .

The **cube root** of a number n , denoted $\sqrt[3]{n}$, is a number whose cube is n .

Any whole number that can be represented as the volume of a cube with a whole number edge length is a **perfect cube**. The edge length of the cube is the **cube root** of the volume of the cube.

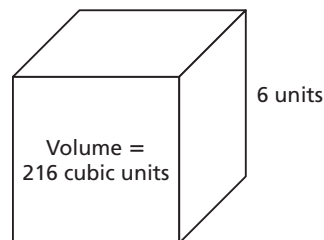

We write: $\sqrt[3]{216} = 6$

216 is a perfect cube and 6 is its cube root.

Example 1 Determining the Square Root of a Whole Number

Determine the square root of 1296.

SOLUTIONS

Method 1

Write 1296 as a product of its prime factors.

$$\begin{aligned} 1296 &= 2 \cdot 2 \cdot 2 \cdot 2 \cdot 3 \cdot 3 \cdot 3 \cdot 3 \\ &= (2 \cdot 2)(2 \cdot 2)(3 \cdot 3)(3 \cdot 3) \\ &= (2 \cdot 2 \cdot 3 \cdot 3)(2 \cdot 2 \cdot 3 \cdot 3) \\ &= 36 \cdot 36 \end{aligned}$$

Group the factors in pairs.
Rearrange the factors in 2 equal groups.

Since 1296 is the product of two equal factors, it can be represented as the area of a square.

So, the square root of 1296 is 36.

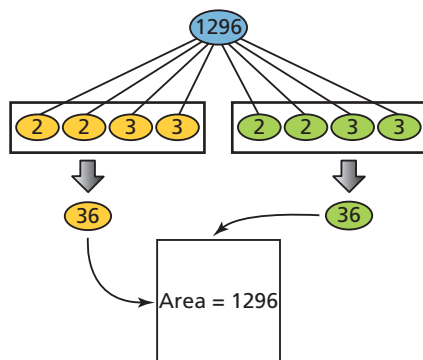

Method 2

Estimate:

$$30^2 = 900 \text{ and } 40^2 = 1600$$

$$900 < 1296 < 1600$$

$$\text{So, } 30 < \sqrt{1296} < 40$$

1296 is about halfway between 900 and 1600.

So, $\sqrt{1296}$ is about halfway between 30 and 40.

Use guess and test to refine the estimate.

Try 35: $35^2 = 1225$ (too small, but close)

Try 36: $36^2 = 1296$

So, the square root of 1296 is 36.

CHECK YOUR UNDERSTANDING

- Determine the square root of 1764.

[Answer: 42]

What if the prime factors cannot be grouped into pairs? What can you say about the number?

Example 2 Determining the Cube Root of a Whole Number

Determine the cube root of 1728.

SOLUTIONS

Method 1

Write 1728 as a product of its prime factors.

$$\begin{aligned}1728 &= 2 \cdot 2 \cdot 2 \cdot 2 \cdot 2 \cdot 2 \cdot 3 \cdot 3 \cdot 3 && \text{Group the factors in sets of 3.} \\ &= (2 \cdot 2 \cdot 2)(2 \cdot 2 \cdot 2)(3 \cdot 3 \cdot 3) && \text{Rearrange the factors in} \\ &= (2 \cdot 2 \cdot 3)(2 \cdot 2 \cdot 3)(2 \cdot 2 \cdot 3) && \text{3 equal groups.} \\ &= 12 \cdot 12 \cdot 12\end{aligned}$$

Since 1728 is the product of three equal factors, it can be represented as the volume of a cube.

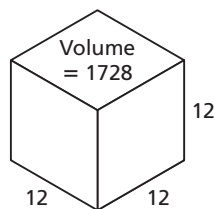

So, the cube root of 1728 is 12.

Method 2

Estimate:

$$10^3 = 1000 \text{ and } 20^3 = 8000$$

$$1000 < 1728 < 8000$$

$$\text{So, } 10 < \sqrt[3]{1728} < 20$$

1728 is closer to 1000 than to 8000.

So, $\sqrt[3]{1728}$ is closer to 10 than to 20.

Use guess and test to refine the estimate.

$$\text{Try 11: } 11^3 = 1331 \text{ (too small, but close)}$$

$$\text{Try 12: } 12^3 = 1728$$

So, the cube root of 1728 is 12.

CHECK YOUR UNDERSTANDING

2. Determine the cube root of 2744.

[Answer: 14]

How could you use this strategy to show a number is not a perfect cube?

Can a whole number be both a perfect square and a perfect cube? Explain.

In *Example 1*, $\sqrt{1296}$ is a radical with radicand 1296. The square root can be written as $\sqrt[2]{1296}$, with index 2, but the index on a square root is implied and often not written.

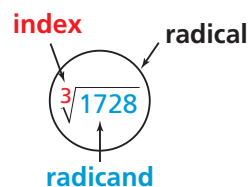

Example 3 Using Roots to Solve a Problem

A cube has volume 4913 cubic inches. What is the surface area of the cube?

SOLUTION

Sketch a diagram.

To calculate the surface area, first determine the edge length of the cube.

The edge length e , of a cube is equal to the cube root of its volume.

$$e = \sqrt[3]{4913}$$

$$e = 17$$

The surface area, SA , of a cube is the sum of the areas of its 6 congruent square faces.

$$SA = 6(17 \cdot 17)$$

$$SA = 6(289)$$

$$SA = 1734$$

The surface area of the cube is 1734 square inches.

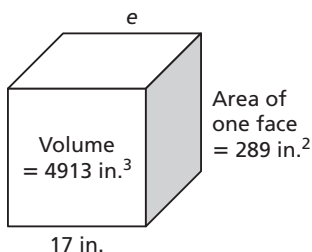

CHECK YOUR UNDERSTANDING

3. A cube has volume 12 167 cubic feet. What is the surface area of the cube?

[Answer: 3174 square feet]

Discuss the Ideas

1. What strategies might you use to determine if a number is a perfect square or a perfect cube?
2. What strategy could you use to determine that a number is not a perfect square? Not a perfect cube?
3. What strategies can you use to determine the square root of a perfect square?
What strategies can you use to determine the cube root of a perfect cube?

Exercises

A

4. Determine the square root of each number.
Explain the process used.
a) 196 b) 256 c) 361 d) 289 e) 441
5. Determine the cube root of each number.
Explain the process used.
a) 343 b) 512 c) 1000 d) 1331 e) 3375

B

6. Use factoring to determine whether each number is a perfect square, a perfect cube, or neither.
a) 225 b) 729 c) 1944
d) 1444 e) 4096 f) 13 824

7. Determine the side length of each square.

a)

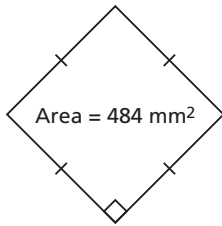

b)

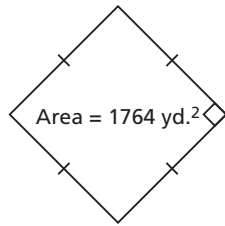

8. Determine the edge length of each cube.

a)

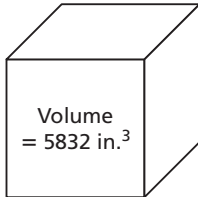

b)

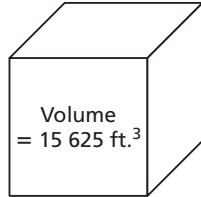

9. In February 2003, the Battlefords Chamber of Commerce in Saskatchewan placed a cage containing a 64-cubic foot ice cube along Yellowhead Highway. Local customers were asked to predict when the ice cube would melt enough for a ball above the ice cube to fall through it. What was the surface area of the cube?



10. A cube has surface area 6534 square feet. What is its volume?
11. Is it possible to construct a cube with 2000 interlocking cubes? Justify your answer.
12. Determine all the perfect square whole numbers and perfect cube whole numbers between each pair of numbers:
- a) 315 – 390 b) 650 – 750
c) 800 – 925 d) 1200 – 1350
13. Write 3 numbers that are both perfect squares and perfect cubes.

14. During the Festival du Voyageur in Winnipeg, Manitoba, teams compete in a snow sculpture competition. Each team begins with a 1440-cubic foot rectangular prism of snow. The prism has a square cross-section and height 10 ft. What are its length and width?



C

15. a) Write an expression for the surface area of this tent. Do not include the floor.

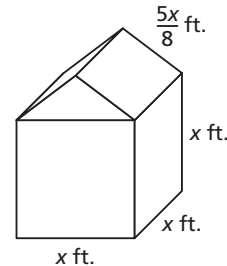

- b) Suppose the surface area of the tent is 90 square feet. Calculate the value of x .
16. Determine the dimensions of a cube for which its surface area is numerically the same as its volume.
17. a) Determine the side length of a square with area $121x^4y^2$.
b) Determine the edge length of a cube with volume $64x^6y^3$.
18. Which pairs of perfect cubes have a sum of 1729?

Reflect

How is determining the square root of a number similar to determining its cube root? How are the strategies different?



CHECKPOINT 1

Connections

Concept Development

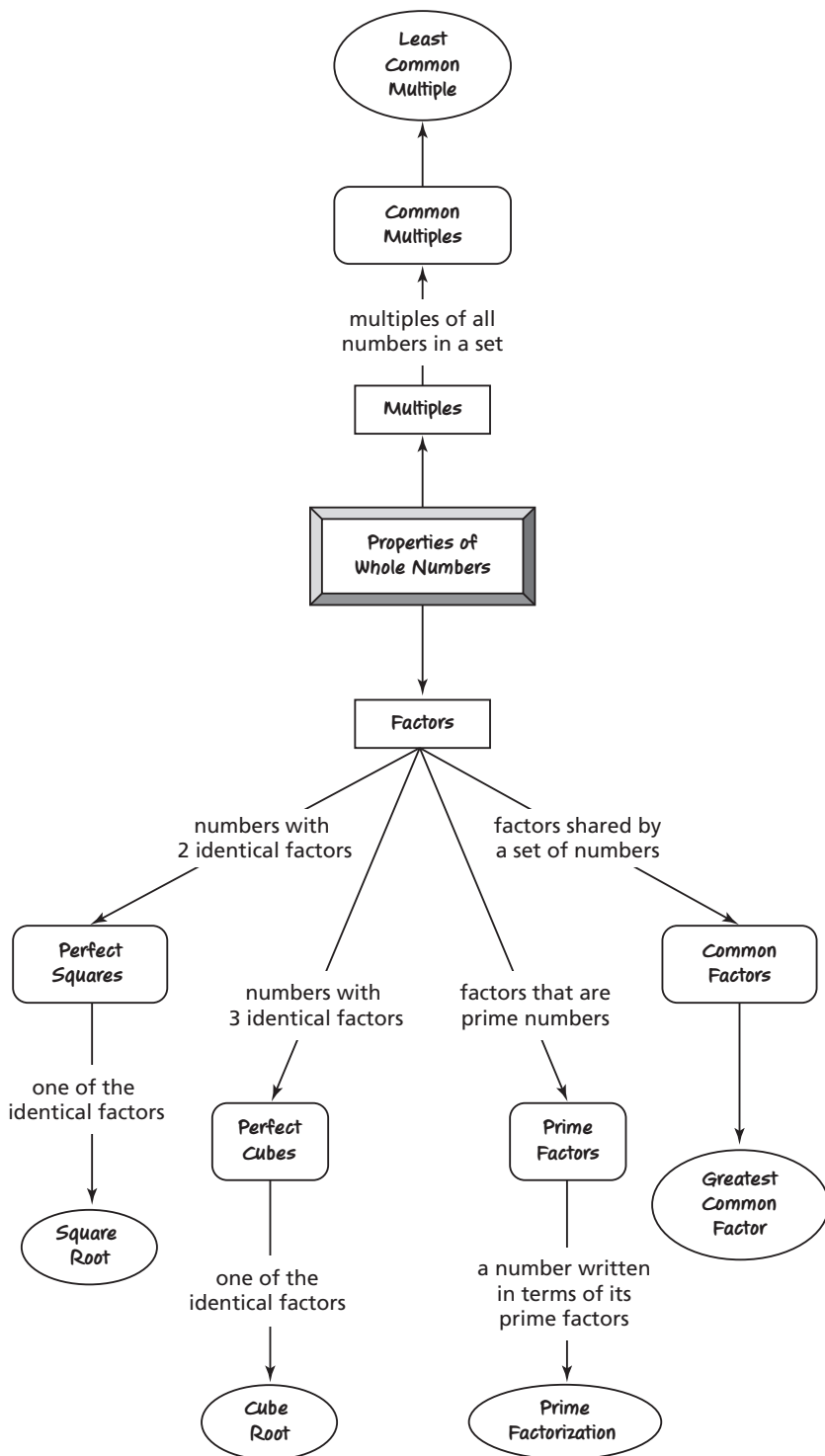

■ In Lesson 3.1

- You applied whole number properties and operations to determine **prime factors**.
- You used prime factors to determine **greatest common factor (GCF)** and **least common multiple (LCM)**.

■ In Lesson 3.2

- You used factors and multiples to determine **perfect square whole numbers** and their **square roots**.
- You used factors and multiples to determine **perfect cube whole numbers** and their **cube roots**.

Assess Your Understanding

3.1

- Use powers to write each number as a product of its prime factors.
 - 1260
 - 4224
 - 6120
 - 1045
 - 3024
 - 3675
- Determine the greatest common factor of each set of numbers.
 - 40, 48, 56
 - 84, 120, 144
 - 145, 205, 320
 - 208, 368, 528
 - 856, 1200, 1368
 - 950, 1225, 1550
- Determine the least common multiple of each set of numbers.
 - 12, 15, 21
 - 12, 20, 32
 - 18, 24, 30
 - 30, 32, 40
 - 49, 56, 64
 - 50, 55, 66
- Use the least common multiple to help determine each answer.
 - $\frac{8}{3} + \frac{5}{11}$
 - $\frac{13}{5} - \frac{4}{7}$
 - $\frac{9}{10} \div \frac{7}{3}$
- The Mayan used several different calendar systems; one system used 365 days, another system used 260 days. Suppose the first day of both calendars occurred on the same day. After how many days would they again occur on the same day? About how long is this in years? Assume 1 year has 365 days.

3.2

- Determine the square root of each number. Which different strategies could you use?
 - 400
 - 784
 - 576
 - 1089
 - 1521
 - 3025
- Determine the cube root of each number. Which different strategies could you use?
 - 1728
 - 3375
 - 8000
 - 5832
 - 10 648
 - 9261
- Determine whether each number is a perfect square, a perfect cube, or neither.
 - 2808
 - 3136
 - 4096
 - 4624
 - 5832
 - 9270
- Between each pair of numbers, identify all the perfect squares and perfect cubes that are whole numbers.
 - 400 – 500
 - 900 – 1000
 - 1100 – 1175
- A cube has a volume of 2197 m^3 . Its surface is to be painted. Each can of paint covers about 40 m^2 . How many cans of paint are needed? Justify your answer.

3.3 Common Factors of a Polynomial

LESSON FOCUS

Model and record factoring a polynomial.

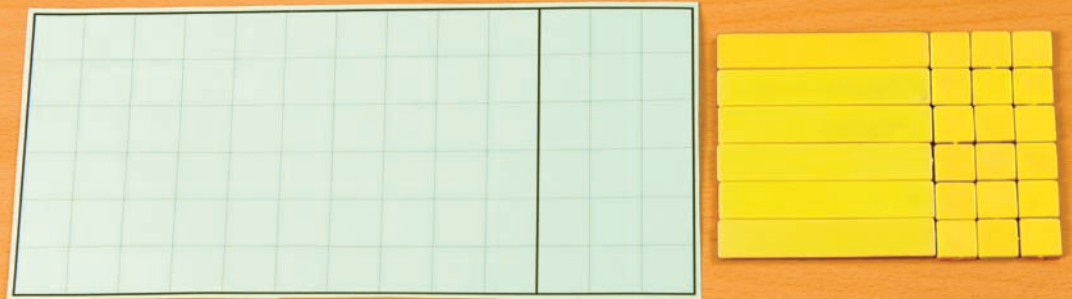

Make Connections

Diagrams and models can be used to represent products.

What multiplication sentences are represented above?

What property do the diagrams illustrate?

Construct Understanding

The variable algebra tile can represent any variable we like. It is usually referred to as the x -tile.

THINK ABOUT IT

You may need algebra tiles.

Sketch all the ways you can arrange these tiles to form a rectangle.



Beside each sketch, write the multiplication sentence it represents.

Each set of tiles below represents the polynomial $4m + 12$.

The dimensions of each rectangle represent the *factors* of the polynomial.

■ $1(4m + 12) = 4m + 12$



■ $2(2m + 6) = 4m + 12$

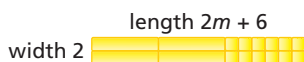

■ $4(m + 3) = 4m + 12$

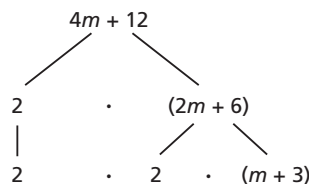
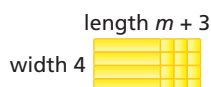

When we write a polynomial as a product of factors, we *factor* the polynomial.

The diagrams above show that there are 3 ways to factor the expression $4m + 12$.

The first two ways: $4m + 12 = 1(4m + 12)$ and $4m + 12 = 2(2m + 6)$ are incomplete because the second factor in each case can be factored further.

That is, neither 1 nor 2 is the greatest common factor of $4m$ and 12.

The third way: $4m + 12 = 4(m + 3)$ is complete. The greatest common factor of $4m$ and 12 is 4.

We say that $4m + 12$ is *factored fully* when we write $4m + 12 = 4(m + 3)$; that is, the polynomial cannot be factored further.

Compare multiplying and factoring in arithmetic and algebra.

In Arithmetic	In Algebra
<p><i>Multiply</i> factors to form a product.</p> $(4)(7) = 28$	<p><i>Expand</i> an expression to form a product.</p> $3(2 - 5a) = 6 - 15a$
<p><i>Factor</i> a number by writing it as a product of factors.</p> $28 = (4)(7)$	<p><i>Factor</i> a polynomial by writing it as a product of factors.</p> $6 - 15a = 3(2 - 5a)$

Factoring and expanding are inverse processes.

Example 1 Using Algebra Tiles to Factor Binomials

Factor each binomial.

a) $6n + 9$

b) $6c + 4c^2$

SOLUTIONS

a) $6n + 9$

Method 1

Arrange algebra tiles in a rectangle.

The dimensions of the rectangle are 3 and $2n + 3$.

$$\text{So, } 6n + 9 = 3(2n + 3)$$

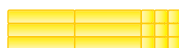

Method 2

Use a factor tree.

$$6n + 9 = 3(2n + 3)$$

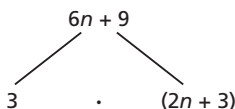

b) $6c + 4c^2$

Method 1

Use algebra tiles.

$$6c + 4c^2 = 2c(3 + 2c)$$



Method 2

Use the greatest common factor.

Factor each term of the binomial.

$$6c = 2 \cdot 3 \cdot c$$

$$4c^2 = 2 \cdot 2 \cdot c \cdot c$$

The greatest common factor is $2c$.

Write each term as a product of $2c$ and another monomial.

$$6c + 4c^2 = 2c(3) + 2c(2c)$$

Use the distributive property to write the sum as a product.

$$6c + 4c^2 = 2c(3 + 2c)$$

CHECK YOUR UNDERSTANDING

1. Factor each binomial.

a) $3g + 6$ b) $8d + 12d^2$

[Answers: a) $3(g + 2)$

b) $4d(2 + 3d)$]

How can you check that your answer is correct?

When a polynomial has negative terms or 3 different terms, we cannot remove a common factor by arranging the tiles as a rectangle. Instead, we can sometimes arrange the tiles into equal groups.

Example 2 Factoring Trinomials

Factor the trinomial $5 - 10z - 5z^2$.

Verify that the factors are correct.

SOLUTIONS

$$5 - 10z - 5z^2$$

Method 1

Use algebra tiles. Arrange five 1-tiles, 10 negative z -tiles, and 5 negative z^2 -tiles into equal groups.

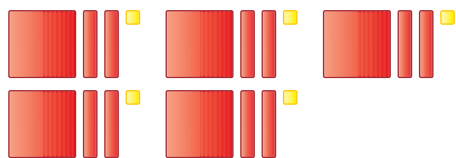

There are 5 equal groups and each group contains the trinomial $1 - 2z - z^2$.

So, the factors are 5 and $1 - 2z - z^2$.

$$5 - 10z - 5z^2 = 5(1 - 2z - z^2)$$

Method 2

Use the greatest common factor.
Factor each term of the trinomial.

$$5 = 5$$

$$10z = 2 \cdot 5 \cdot z$$

$$5z^2 = 5 \cdot z \cdot z$$

The greatest common factor is 5. Write each term as a product of the greatest common factor and another monomial.

$$5 - 10z - 5z^2 = 5(1) - 5(2z) - 5(z^2)$$

Use the distributive property to write the expression as a product.

$$5 - 10z - 5z^2 = 5(1 - 2z - z^2)$$

$$\begin{aligned} \text{Check: Expand } 5(1 - 2z - z^2) &= 5(1) - 5(2z) - 5(z^2) \\ &= 5 - 10z - 5z^2 \end{aligned}$$

This trinomial is the same as the original trinomial, so the factors are correct.

CHECK YOUR UNDERSTANDING

- Factor the trinomial $6 - 12z + 18z^2$.
Verify that the factors are correct.

[Answer: $6(1 - 2z + 3z^2)$]

When you have factored an expression, why should you always use the distributive property to expand the product?

Another strategy used in factoring polynomials is to identify and factor out any common factors.

Example 3 Factoring Polynomials in More than One Variable

Factor the trinomial. Verify that the factors are correct.

$$-12x^3y - 20xy^2 - 16x^2y^2$$

SOLUTION

$$-12x^3y - 20xy^2 - 16x^2y^2$$

Factor each term of the trinomial.

$$12x^3y = 2 \cdot 2 \cdot 3 \cdot x \cdot x \cdot x \cdot y$$

$$20xy^2 = 2 \cdot 2 \cdot 5 \cdot x \cdot y \cdot y$$

$$16x^2y^2 = 2 \cdot 2 \cdot 2 \cdot 2 \cdot x \cdot x \cdot y \cdot y$$

The greatest common factor is: $2 \cdot 2 \cdot x \cdot y = 4xy$

Write each term as a product of the greatest common factor and another monomial.

$$-12x^3y - 20xy^2 - 16x^2y^2$$

$$= 4xy(-3x^2) - 4xy(5y) - 4xy(4xy) \quad \text{Write the expression as a product.}$$

$$= 4xy(-3x^2 - 5y - 4xy)$$

$$= 4xy(-1)(3x^2 + 5y + 4xy)$$

$$= -4xy(3x^2 + 5y + 4xy)$$

Check: Expand $-4xy(3x^2 + 5y + 4xy)$

$$= (-4xy)(3x^2) + (-4xy)(5y) + (-4xy)(4xy)$$

$$= -12x^3y - 20xy^2 - 16x^2y^2$$

This trinomial is the same as the original trinomial, so the factors are correct.

CHECK YOUR UNDERSTANDING

3. Factor the trinomial. Verify that the factors are correct.

$$-20c^4d - 30c^3d^2 - 25cd$$

$$[\text{Answer: } -5cd(4c^3 + 6c^2d + 5)]$$

What other strategies could you use?

In *Example 3*, the common factor -1 was removed because every term was negative. When we factor a polynomial that has negative terms, we usually ensure that the first term inside the brackets is positive.

Discuss the Ideas

1. How is using an algebra tile model to multiply a polynomial by a monomial like using an area model to multiply two whole numbers?
2. How are the strategies used to factor a polynomial like those used to determine the prime factorization of a whole number?
3. Can every binomial be factored? Explain.

Exercises

A

4. For each arrangement of algebra tiles, write the polynomial they represent and identify its factors.

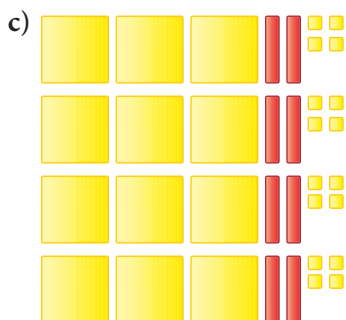

5. Factor the terms in each set, then identify the greatest common factor.

a) 6, 15n b) 4m, m²

6. Use the greatest common factors from question 5 to factor each expression.

a) i) 6 + 15n ii) 6 - 15n
 iii) 15n - 6 iv) -15n + 6
 b) i) 4m + m² ii) m² + 4m
 iii) 4m - m² iv) m² - 4m

B

7. Use algebra tiles to factor each binomial. Sketch the tiles you used.

a) 5y + 10 b) 6 + 12x²
 c) 9k + 6 d) 4s² + 14s
 e) y + y² f) 3h + 7h²

8. Factor each binomial. Why can you not use algebra tiles? Check by expanding.

a) 9b² - 12b³ b) 48s³ - 12
 c) -a² - a³ d) 3x² + 6x⁴
 e) 8y³ - 12y f) -7d - 14d⁴

9. Use algebra tiles to factor each trinomial. Sketch the tiles you used.

a) 3x² + 12x - 6 b) 4 - 6y - 8y²
 c) -7m - 7m² - 14 d) 10n - 6 - 12n²
 e) 8 + 10x + 6x² f) -9 + 12b + 6b²

10. Factor each trinomial. Why can you not use algebra tiles? Check by expanding.

a) 5 + 15m² - 10m³ b) 27n + 36 - 18n³
 c) 6v⁴ + 7v - 8v³ d) -3c² - 13c⁴ - 12c³
 e) 24x + 30x² - 12x⁴ f) s⁴ + s² - 4s

11. a) Write the polynomial these algebra tiles represent.

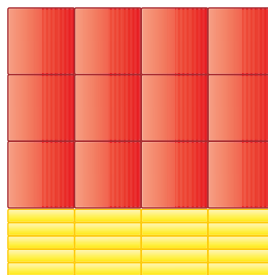

- b) Factor the polynomial.
 c) Compare the factors with the dimensions of the rectangle. What do you notice?

12. a) Here are a student's solutions for factoring polynomials. Identify the errors in each solution. Write a correct solution.

i) Factor: 3m² + 9m³ - 3m
 Solution: 3m² + 9m³ - 3m = 3m(m + 3m²)

ii) Factor: -16 + 8n - 4n³
 Solution: -16 + 8n - 4n³ = -4(4 + 2n + n²)

- b) What should the student have done to check his work?

13. Suppose you are writing each term of a polynomial as the product of a common factor and a monomial. When is the monomial 1? When is the monomial -1?

14. Simplify each expression by combining like terms, then factor.

a) x² + 6x - 7 - x² - 2x + 3
 b) 12m² - 24m - 3 + 4m² - 13
 c) -7n³ - 5n² + 2n - n² - n³ - 12n

15. a) Factor the terms in each set, then identify the greatest common factor.
- $4s^2t^2, 12s^2t^3, 36st^2$
 - $3a^3b, 8a^2b, 9a^4b$
 - $12x^3y^2, 12x^4y^3, 36x^2y^4$
- b) Use the greatest common factors from part a to factor each trinomial.
- $4s^2t^2 + 12s^2t^3 + 36st^2$
 - $12s^2t^3 - 4s^2t^2 - 36st^2$
 - $-3a^3b - 9a^4b + 8a^2b$
 - $9a^4b + 3a^3b - 8a^2b$
 - $36x^2y^4 + 12x^3y^2 + 12x^4y^3$
 - $-36x^2y^4 - 12x^4y^3 - 12x^3y^2$

16. Factor each trinomial. Check by expanding.

- $25xy + 15x^2 - 30x^2y^2$
- $51m^2n + 39mn^2 - 72mn$
- $9p^4q^2 - 6p^3q^3 + 12p^2q^4$
- $10a^3b^2 + 12a^2b^4 - 5a^2b^2$
- $12cd^2 - 8cd - 20c^2d$
- $7r^3s^3 + 14r^2s^2 - 21rs^2$

17. A formula for the surface area, SA , of a cylinder with base radius r and height h is:

$$SA = 2\pi r^2 + 2\pi rh$$

- Factor this formula.
 - Use both forms of the formula to calculate the surface area of a cylinder with base radius 12 cm and height 23 cm. Is one form of the formula more efficient to use than the other? Explain.
18. A formula for the surface area, SA , of a cone with slant height s and base radius r is:

$$SA = \pi r^2 + \pi rs$$

- Factor this formula.
- Use both forms of the formula to calculate the surface area of a cone with base radius 9 cm and slant height 15 cm. Is one form of the formula more efficient to use than the other? Explain.

19. A silo has a cylindrical base with height h and radius r , and a hemispherical top.

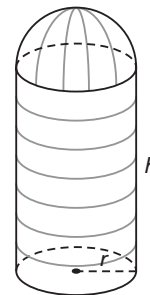

- Write an expression for the surface area of the silo. Factor the expression. Determine the surface area of the silo when its base radius is 6 m and the height of the cylinder is 10 m. Which form of the expression will you use? Explain why.
 - Write an expression for the volume of the silo. Factor the expression. Use the values of the radius and height from part a to calculate the volume of the silo. Which form of the expression will you use? Explain why.
20. Suppose n is an integer. Is $n^2 - n$ always an integer? Justify your answer.

C

21. A cylindrical bar has base radius r and height h . Only the curved surface of a cylindrical bar is to be painted.
- Write an expression for the fraction of the total surface area that will be painted.
 - Simplify the fraction.
22. A diagonal of a polygon is a line segment joining non-adjacent vertices.
- How many diagonals can be drawn from one vertex of a pentagon? A hexagon?
 - Suppose the polygon has n sides. How many diagonals can be drawn from one vertex?
 - The total number of diagonals of a polygon with n sides is $\frac{n^2}{2} - \frac{3n}{2}$. Factor this formula. Explain why it is reasonable.

Reflect

If a polynomial factors as a product of a monomial and a polynomial, how can you tell when you have factored it fully?

**LESSON FOCUS**

Explore factoring polynomials with algebra tiles.

Make Connections

We can use an area model and the distributive property to illustrate the product of two 2-digit numbers.

$$\begin{aligned}
 12 \times 13 &= (10 + 2)(10 + 3) \\
 &= 10(10 + 3) + 2(10 + 3) \\
 &= 10(10) + 10(3) + 2(10) + 2(3) \\
 &= 100 + 30 + 20 + 6 \\
 &= 156
 \end{aligned}$$

How could you use an area model to identify the binomial factors of a trinomial?

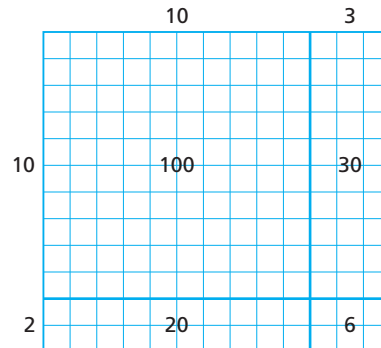
**Construct Understanding****TRY THIS**

You will need algebra tiles. Use only positive tiles.

- A.** Use 1 x^2 -tile, and a number of x -tiles and 1-tiles.
- Arrange the tiles to form a rectangle. If you cannot make a rectangle, use additional x - and 1-tiles as necessary. For each rectangle, sketch the tiles and write the multiplication sentence it represents.
 - Choose a different number of x -tiles and 1-tiles and repeat until you have 4 different multiplication sentences.

- B.** Use 2 or more x^2 -tiles and a number of x -tiles and 1-tiles.
- Arrange the tiles to form a rectangle. Use additional x - and 1-tiles if necessary. For each rectangle, sketch the tiles and write the corresponding multiplication sentence.
 - Repeat with different numbers of tiles until you have 4 different multiplication sentences.
- C.** Share your work with a classmate. What patterns do you see in the products and factors?

Assess Your Understanding

1. Which of the following trinomials can be represented by a rectangle? Use algebra tiles to check. Sketch each rectangle.

a) $y^2 + 4y + 3$	b) $d^2 + 7d + 10$	c) $m^2 + 7m + 7$
d) $r^2 + 14r + 14$	e) $t^2 + 6t + 6$	f) $p^2 + 9p + 2$
2. Which of the following trinomials can be represented by a rectangle? Use algebra tiles to check your answers. Sketch each rectangle.

a) $2s^2 + 7s + 3$	b) $3w^2 + 5w + 2$	c) $2f^2 + 3f + 2$
d) $2h^2 + 10h + 6$	e) $4n^2 + 2n + 1$	f) $6k^2 + 11k + 3$
3. Suppose you must use 1 x^2 -tile and twelve 1-tiles. Which numbers of x -tiles could you use to form a rectangle?
4. Suppose you must use 2 x^2 -tiles and 9 x -tiles. Which numbers of 1-tiles could you use to form a rectangle?



THE WORLD OF MATH

Math Fact: Taylor Polynomials

A certain type of polynomial is named for the English mathematician Brook Taylor, 1685–1731. Taylor polynomials are used to determine approximate values.

When you use the square root key on a scientific calculator, you are seeing Taylor polynomials in action. The square root of a number between 0 and 2 can be approximated using this polynomial:

$$\sqrt{x} \doteq 1 + \frac{1}{2}(x - 1) - \frac{1}{8}(x - 1)^2 + \frac{1}{16}(x - 1)^3 - \frac{5}{128}(x - 1)^4$$

Use the polynomial to estimate the value of $\sqrt{1.5}$.

Use a calculator to determine how many digits of your answer are correct.

3.5 Polynomials of the Form $x^2 + bx + c$

LESSON FOCUS

Use models and algebraic strategies to multiply binomials and to factor trinomials.

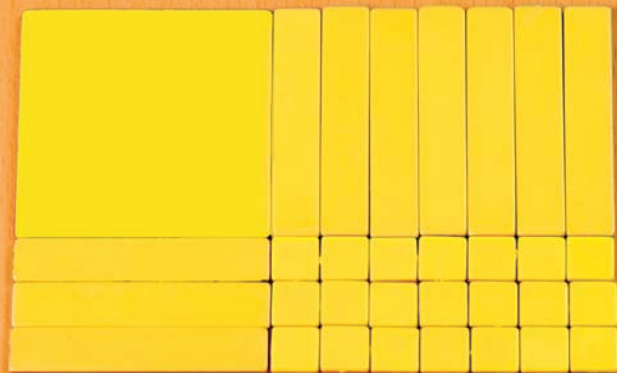

Make Connections

How is each term in the trinomial below represented in the algebra tile model above?

$$(c + 3)(c + 7) = c^2 + 10c + 21$$

Construct Understanding

TRY THIS

Work with a partner.

- Sketch a rectangle to illustrate each product. Write a multiplication sentence that relates the factors to the final product.

$$(c + 4)(c + 2) \quad (c + 4)(c + 3) \quad (c + 4)(c + 4) \quad (c + 4)(c + 5)$$

- Describe a pattern that relates the coefficients of the terms in the factors to the coefficients in the product.
- Use the patterns you identified. Take turns to write two binomials, then sketch a rectangle to determine their product.
- Describe a strategy you could use to multiply two binomials, without sketching a rectangle.

When two binomials contain only positive terms, here are two strategies to determine the product of the binomials.

Use algebra tiles.

To expand: $(c + 5)(c + 3)$

Make a rectangle with dimensions $c + 5$ and $c + 3$.

Place tiles to represent each dimension, then fill in the rectangle with tiles.

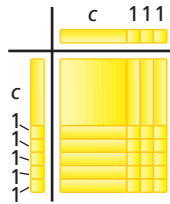

The tiles that form the product are: 1 c^2 -tile, 8 c -tiles, and fifteen 1-tiles.

$$\text{So, } (c + 5)(c + 3) = c^2 + 8c + 15$$

Use an area model.

To expand: $(h + 11)(h + 5)$

Sketch a rectangle with dimensions $h + 11$ and $h + 5$.

Divide the rectangle into 4 smaller rectangles and calculate the area of each.

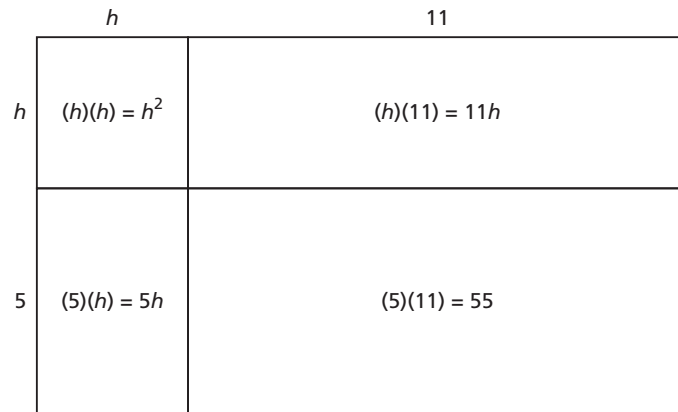

$$\begin{aligned} \text{So, } (h + 11)(h + 5) &= h^2 + 5h + 11h + 55 && \text{Combine like terms.} \\ &= h^2 + 16h + 55 \end{aligned}$$

Note that $(h + 11)(h + 5) = (h + 5)(h + 11)$ since both products represent the area of the same rectangle.

This strategy shows that there are 4 terms in the product. These terms are formed by applying the distributive property and multiplying each term in the first binomial by each term in the second binomial.

$$(h + 11)(h + 5) = h^2 + 5h + 11h + 55$$

When binomials contain negative terms, it is not easy to determine their product using algebra tiles. We cannot determine the product using an area model because a negative area does not exist, but we can use a rectangle diagram. We can also use the distributive property.

Example 1 Multiplying Two Binomials

Expand and simplify.

a) $(x - 4)(x + 2)$ b) $(8 - b)(3 - b)$

SOLUTIONS

a) $(x - 4)(x + 2)$

Method 1

Use a rectangle diagram.

	x	2
x	$(x)(x) = x^2$	$(x)(2) = 2x$
-4	$(-4)(x) = -4x$	$(-4)(2) = -8$

$$\begin{aligned}(x - 4)(x + 2) &= x^2 + (-4x) + 2x + (-8) && \text{Combine like terms.} \\ &= x^2 - 2x - 8\end{aligned}$$

Method 2

Use the distributive property.

$$\begin{aligned}(x - 4)(x + 2) &= x(x + 2) + (-4)(x + 2) \\ &= x(x) + x(2) + (-4)(x) + (-4)(2) \\ &= x^2 + 2x - 4x - 8 && \text{Combine like terms.} \\ &= x^2 - 2x - 8\end{aligned}$$

b) $(8 - b)(3 - b)$

Use the distributive property.

$$\begin{aligned}(8 - b)(3 - b) &= 8(3 - b) + (-b)(3 - b) \\ &= 8(3) + 8(-b) + (-b)(3) + (-b)(-b) \\ &= 24 - 8b - 3b + b^2 \\ &= 24 - 11b + b^2\end{aligned}$$

CHECK YOUR UNDERSTANDING

1. Expand and simplify.

a) $(c + 3)(c - 7)$

b) $(5 - s)(9 - s)$

[Answers: a) $c^2 - 4c - 21$
b) $45 - 14s + s^2$]

How do the constant terms in the binomial factors relate to the middle term and the last term in the trinomial product? How can you use these relationships to determine the product?

Factoring and multiplying are inverse processes. We can use this to factor a trinomial.

When a trinomial contains only positive terms, we may use algebra tiles to factor it.

For example: to factor $v^2 + 12v + 20$, arrange the tiles that represent these terms in a rectangle. Place the v^2 -tile in the top left, then arrange the v -tiles to the right and beneath this tile so the 1-tiles fit in the space that is left.

How does the use of algebra tiles for factoring relate to the area model for multiplication?



$$\text{So, } v^2 + 12v + 20 = (v + 2)(v + 10)$$

We say that the factors of $v^2 + 12v + 20$ are $v + 2$ and $v + 10$.

Look at the numbers in the trinomial and the binomial.

$$v^2 + 12v + 20 = (v + 2)(v + 10)$$

12 is the sum of 2 and 10.

20 is the product of 2 and 10.

How could you complete this factorization?

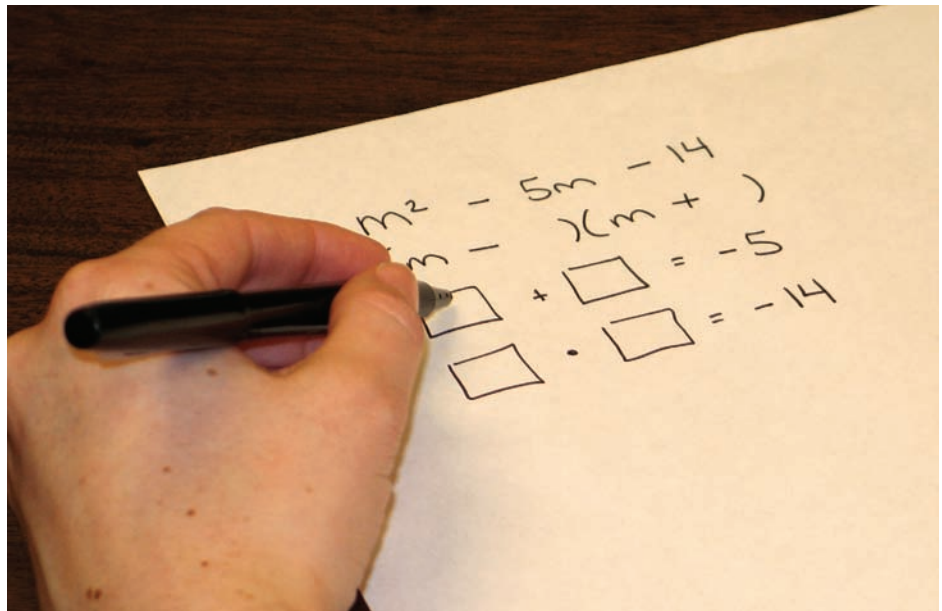

Factoring a Trinomial

To determine the factors of a trinomial of the form $x^2 + bx + c$, first determine two numbers whose sum is b and whose product is c . These numbers are the constant terms in two binomial factors, each of which has x as its first term.

Example 2 Factoring Trinomials

Factor each trinomial.

a) $x^2 - 2x - 8$

b) $z^2 - 12z + 35$

SOLUTION

a) $x^2 - 2x - 8$

Since factoring and expanding are inverse processes, there will be two binomial factors.

They will have the form: $(x + \text{an integer})(x + \text{an integer})$

The two integers in the binomials have a sum of -2 and a product of -8 .

To determine the integers, list pairs of factors of -8 , then add the factors in each pair.

Since the product is negative, the factors have different signs.

Factors of -8	Sum of Factors
$-1, 8$	$-1 + 8 = 7$
$1, -8$	$1 - 8 = -7$
$-2, 4$	$-2 + 4 = 2$
$2, -4$	$2 - 4 = -2$

The factors that have a sum of -2 are 2 and -4 .

Write these integers as the second terms in the binomials.

$$x^2 - 2x - 8 = (x + 2)(x - 4)$$

b) $z^2 - 12z + 35$

Find two integers whose sum is -12 and whose product is 35 .

Since the product is positive, the factors have the same sign.

Factors of 35	Sum of Factors
$1, 35$	$1 + 35 = 36$
$-1, -35$	$-1 - 35 = -36$
$5, 7$	$5 + 7 = 12$
$-5, -7$	$-5 - 7 = -12$

The factors that have a sum of -12 are -5 and -7 .

$$z^2 - 12z + 35 = (z - 5)(z - 7)$$

CHECK YOUR UNDERSTANDING

2. Factor each trinomial.

a) $x^2 - 8x + 7$

b) $a^2 + 7a - 18$

[Answers: a) $(x - 7)(x - 1)$

b) $(a + 9)(a - 2)$]

Does the order in which the binomial factors are written affect the solution? Explain. Why do we list all the factors for the given product rather than all the numbers that have the given sum?

We should always check that the binomial factors are correct by expanding the product.

For *Example 2b*, expand $(z - 5)(z - 7)$.

$$\begin{aligned}(z - 5)(z - 7) &= z(z - 7) - 5(z - 7) \\ &= z^2 - 7z - 5z + 35 \\ &= z^2 - 12z + 35\end{aligned}$$

Since this trinomial is the same as the original trinomial, the factors are correct.

The trinomials in *Example 2* are written in *descending order*; that is, the terms are written in order from the term with the greatest exponent to the term with the least exponent.

When the order of the terms is reversed, the terms are written in *ascending order*.

Example 3 Factoring a Trinomial Written in Ascending Order

Factor: $-24 - 5d + d^2$

SOLUTIONS

Method 1

$$-24 - 5d + d^2$$

The binomials will have the form:
(an integer + d)(an integer + d)

Find two integers whose product is -24 and whose sum is -5 .

The integers are -8 and 3 .

$$\text{So, } -24 - 5d + d^2 = (-8 + d)(3 + d)$$

Method 2

Rewrite the polynomial in descending order.

$$-24 - 5d + d^2 = d^2 - 5d - 24$$

Find two integers whose product is -24 and whose sum is -5 .

The integers are -8 and 3 .

$$d^2 - 5d - 24 = (d - 8)(d + 3)$$

CHECK YOUR UNDERSTANDING

3. Factor: $-30 + 7m + m^2$

[Answer: $(-3 + m)(10 + m)$]

Is the answer obtained in Method 1 equivalent to that obtained in Method 2? Does the order we write the terms of the binomial matter? Why or why not?

A trinomial that can be written as the product of two binomial factors may also have a common factor.

Example 4 Factoring a Trinomial with a Common Factor and Binomial Factors

Factor.

$$-4t^2 - 16t + 128$$

SOLUTION

$$-4t^2 - 16t + 128$$

The greatest common factor is 4. Since the coefficient of the first term is negative, use -4 as the common factor.

$$-4t^2 - 16t + 128 = -4(t^2 + 4t - 32)$$

Two numbers with a sum of 4 and a product of -32 are -4 and 8.

$$\text{So, } t^2 + 4t - 32 = (t - 4)(t + 8)$$

$$\text{And, } -4t^2 - 16t + 128 = -4(t - 4)(t + 8)$$

Since factoring and expanding are inverse processes, check that the factors are correct. Multiply the factors.

$$\begin{aligned} -4(t - 4)(t + 8) &= -4(t^2 + 4t - 32) \\ &= -4t^2 - 16t + 128 \end{aligned}$$

This trinomial is the same as the original trinomial, so the factors are correct.

CHECK YOUR UNDERSTANDING

4. Factor.

$$-5h^2 - 20h + 60$$

$$[\text{Answer: } -5(h - 2)(h + 6)]$$

What other ways can you write the trinomial as a product of 3 factors?

When we compare factors of a trinomial, it is important to remember that the order in which we add terms does not matter, so $x + a = a + x$, for any integer a . Similarly, the order in which we multiply terms does not matter, so $(x + a)(x + b) = (x + b)(x + a)$.

Discuss the Ideas

1. How is representing the product of two binomials similar to representing the product of two 2-digit numbers?
2. How does a rectangle diagram relate binomial multiplication and trinomial factoring?
3. For the multiplication sentence $x^2 + ax + b = (x + c)(x + d)$, what relationships exist among a , b , c , and d ?

Exercises

A

4. Write the multiplication sentence that each set of algebra tiles represents.

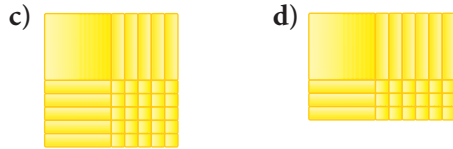

5. Use algebra tiles to determine each product. Sketch the tiles you used.

- a) $(b + 2)(b + 5)$
 b) $(n + 4)(n + 7)$
 c) $(h + 8)(h + 3)$
 d) $(k + 1)(k + 6)$

6. For each set of algebra tiles below:

- i) Write the trinomial that the algebra tiles represent.
 ii) Arrange the tiles to form a rectangle. Sketch the rectangle.
 iii) Use the rectangle to factor the trinomial.

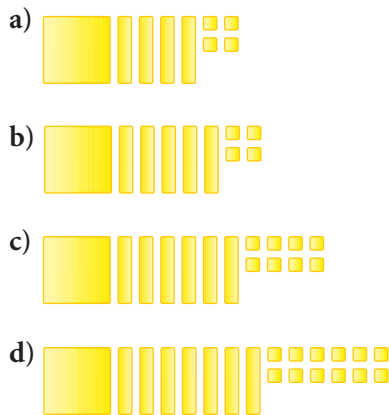

7. a) Find two integers with the given properties.

	a	b	Product ab	Sum $a + b$
i)			2	3
ii)			6	5
iii)			9	10
iv)			10	7
v)			12	7
vi)			15	8

b) Use the results of part a to factor each trinomial.

- i) $v^2 + 3v + 2$ ii) $w^2 + 5w + 6$
 iii) $s^2 + 10s + 9$ iv) $t^2 + 7t + 10$
 v) $y^2 + 7y + 12$ vi) $h^2 + 8h + 15$

B

8. a) Use algebra tiles to factor each trinomial. Sketch the tiles you used.

- i) $v^2 + 2v + 1$ ii) $v^2 + 4v + 4$
 iii) $v^2 + 6v + 9$ iv) $v^2 + 8v + 16$

b) What patterns do you see in the algebra tile rectangles? How are these patterns shown in the binomial factors?

c) Write the next 3 trinomials in the pattern and their binomial factors.

9. Multiply each pair of binomials. Sketch and label a rectangle to illustrate each product.

- a) $(m + 5)(m + 8)$ b) $(y + 9)(y + 3)$
 c) $(w + 2)(w + 16)$ d) $(k + 13)(k + 1)$

10. Copy and complete.

- a) $(w + 3)(w + 2) = w^2 + \square w + 6$
 b) $(x + 5)(x + \square) = x^2 + \circ x + 10$
 c) $(y + \circ)(y + \square) = y^2 + 12y + 20$

11. Factor. Check by expanding.

- a) $x^2 + 10x + 24$ b) $m^2 + 10m + 16$
 c) $p^2 + 13p + 12$ d) $s^2 + 12s + 20$
 e) $n^2 + 12n + 11$ f) $h^2 + 8h + 12$
 g) $q^2 + 7q + 6$ h) $b^2 + 11b + 18$

- 12.** Expand and simplify. Sketch a rectangle diagram to illustrate each product.
- a) $(g - 3)(g + 7)$ b) $(h + 2)(h - 7)$
 c) $(11 - j)(2 - j)$ d) $(k - 3)(k + 11)$
 e) $(12 + h)(7 - h)$ f) $(m - 9)(m + 9)$
 g) $(n - 14)(n - 4)$ h) $(p + 6)(p - 17)$
- 13.** Find and correct the errors in each expansion.
- a) $(r - 13)(r + 4) = r(r + 4) - 13(r + 4)$
 $= r^2 + 4r - 13r + 52$
 $= r^2 + 9r + 52$
- b) $(s - 15)(s - 5) = s(s - 15) + 15(s + 5)$
 $= s^2 - 15s + 15s + 75$
 $= s^2 + 75$
- 14.** Factor. Check by expanding.
- a) $b^2 + 19b - 20$ b) $t^2 + 15t - 54$
 c) $x^2 + 12x - 28$ d) $n^2 - 5n - 24$
 e) $a^2 - a - 20$ f) $y^2 - 2y - 48$
 g) $m^2 - 15m + 50$ h) $a^2 - 12a + 36$
- 15.** Factor. Check by expanding.
- a) $12 + 13k + k^2$ b) $-16 - 6g + g^2$
 c) $60 + 17y + y^2$ d) $72 - z - z^2$
- 16.** a) Simplify each pair of products.
 i) $(x + 1)(x + 2)$ and $11 \cdot 12$
 ii) $(x + 1)(x + 3)$ and $11 \cdot 13$
 b) What are the similarities between the two answers for each pair of products?
- 17.** Find and correct the errors in each factorization.
- a) $m^2 - 7m - 60 = (m - 5)(m - 12)$
 b) $w^2 - 14w + 45 = (w + 3)(w - 15)$
 c) $b^2 + 9b - 36 = (b + 3)(b - 12)$
- 18.** a) Expand each product, then write it as a trinomial.
 i) $(t + 4)(t + 7)$ ii) $(t - 4)(t - 7)$
 iii) $(t - 4)(t + 7)$ iv) $(t + 4)(t - 7)$
 b) i) Why are the constant terms in the trinomials in parts i and ii above positive?
 ii) Why are the constant terms in the trinomials in parts iii and iv above negative?
 iii) How could you determine the coefficient of the t -term in the trinomial without expanding?

- 19.** Find an integer to replace \square so that each trinomial can be factored.
 How many integers can you find each time?
- a) $x^2 + \square x + 10$
 b) $a^2 + \square a - 9$
 c) $t^2 + \square t + 8$
 d) $y^2 + \square y - 12$
 e) $h^2 + \square h + 18$
 f) $p^2 + \square p - 16$
- 20.** Find an integer to replace \square so that each trinomial can be factored.
 How many integers can you find each time?
- a) $r^2 + r + \square$ b) $h^2 - h + \square$
 c) $b^2 + 2b + \square$ d) $z^2 - 2z + \square$
 e) $q^2 + 3q + \square$ f) $g^2 - 3g + \square$
- 21.** Factor.
- a) $4y^2 - 20y - 56$ b) $-3m^2 - 18m - 24$
 c) $4x^2 + 4x - 48$ d) $10x^2 + 80x + 120$
 e) $-5n^2 + 40n - 35$ f) $7c^2 - 35c + 42$

C

- 22.** In this lesson, you used algebra tiles to multiply two binomials and to factor a trinomial when all the terms were positive.
- a) How could you use algebra tiles to expand $(r - 4)(r + 1)$?
 Sketch the tiles you used. Explain your strategy.
- b) How could you use algebra tiles to factor $t^2 + t - 6$?
 Sketch the tiles you used. Explain your strategy.
- 23.** a) Factor each trinomial.
 i) $h^2 - 10h - 24$
 ii) $h^2 + 10h - 24$
 iii) $h^2 - 10h + 24$
 iv) $h^2 + 10h + 24$
 b) In part a, all the trinomials have the same numerical coefficients and constant terms, but different signs. Find other examples like this, in which all 4 trinomials of the form $h^2 \pm bh \pm c$ can be factored.

Reflect

Suppose a trinomial of the form $x^2 + ax + b$ is the product of two binomials. How can you determine the binomial factors?

3.6 Polynomials of the Form $ax^2 + bx + c$

LESSON FOCUS

Extend the strategies for multiplying binomials and factoring trinomials.

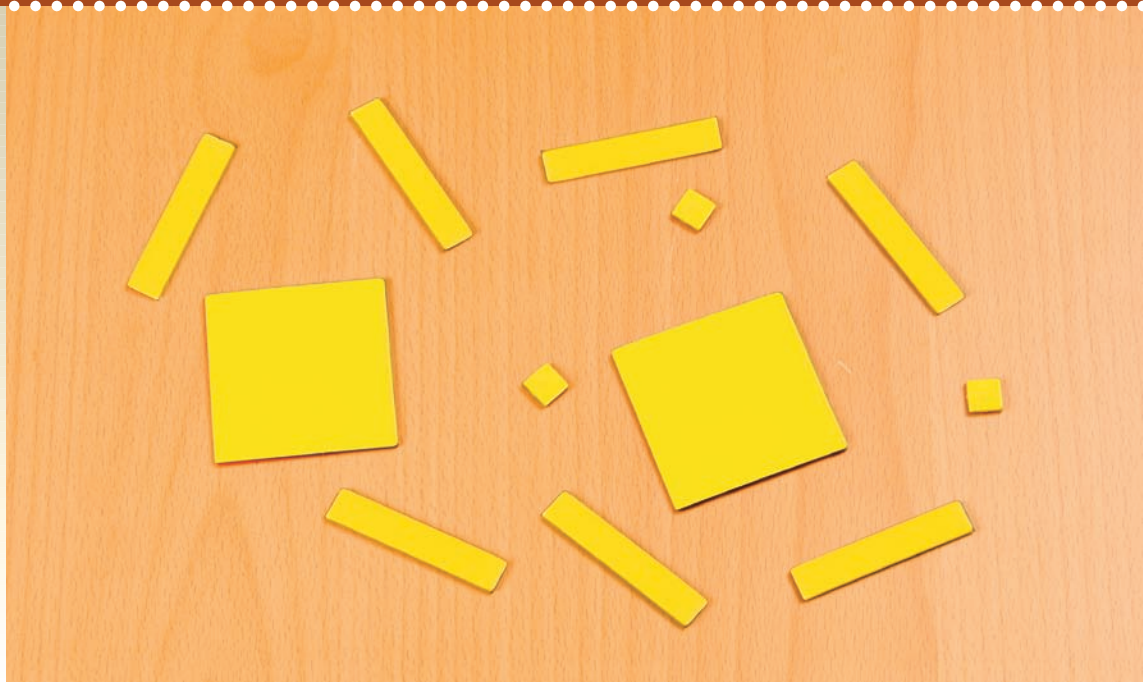

Make Connections

Which trinomial is represented by the algebra tiles shown above?

How can the tiles be arranged to form a rectangle?

Construct Understanding

THINK ABOUT IT

Work with a partner.

You will need algebra tiles.

For which of these trinomials can the algebra tiles be arranged to form a rectangle? For those that can be represented by a rectangular arrangement, write the multiplication sentence.

$$2x^2 + 15x + 7$$

$$2x^2 + 5x + 2$$

$$6x^2 + 7x + 2$$

$$5x^2 + 4x + 4$$

$$2x^2 + 9x + 10$$

$$5x^2 + 11x + 2$$

To multiply two binomials where the coefficients of the variables are not 1, we use the same strategies as for the binomials in Lesson 3.5.

Example 1 Multiplying Two Binomials with Positive Terms

Expand: $(3d + 4)(4d + 2)$

SOLUTIONS

Method 1

Use algebra tiles.

Make a rectangle with dimensions $3d + 4$ and $4d + 2$.

Place tiles to represent each dimension, then fill the rectangle with tiles.

The tiles that form the product represent $12d^2 + 22d + 8$.

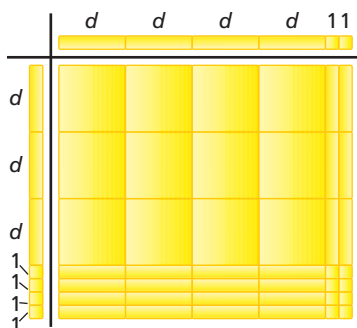

$$\text{So, } (3d + 4)(4d + 2) = 12d^2 + 22d + 8$$

Method 2

Use an area model.

To expand: $(3d + 4)(4d + 2)$, draw a rectangle with dimensions $3d + 4$ and $4d + 2$. Divide the rectangle into 4 smaller rectangles then calculate the area of each.

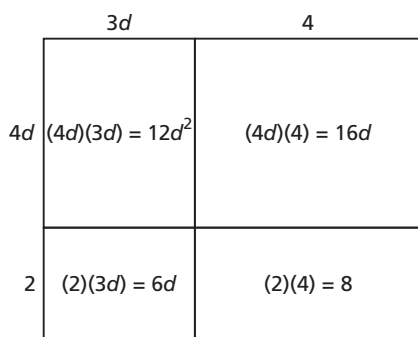

The area of the larger rectangle is the sum of the areas of the smaller rectangles.

$$\begin{aligned} \text{So, } (3d + 4)(4d + 2) &= 12d^2 + 16d + 6d + 8 \\ &= 12d^2 + 22d + 8 \end{aligned}$$

CHECK YOUR UNDERSTANDING

1. Expand: $(5e + 3)(2e + 4)$

[Answer: $10e^2 + 26e + 12$]

This rectangle diagram shows the relationship between the coefficients in the product and the coefficients in the factors for $(ax + b)(cx + d)$.
 $(ax + b)(cx + d) = acx^2 + adx + bcx + bd$

	cx	d
ax	$(ax)(cx) = acx^2$	$(ax)(d) = adx$
b	$(b)(cx) = bcx$	$(b)(d) = bd$

When binomials contain negative terms, it can be difficult to model their product with algebra tiles. We can use the distributive property to determine their product.

Example 2 Multiplying Two Binomials with Negative Coefficients

Expand and simplify: $(-2g + 8)(7 - 3g)$

SOLUTIONS

Method 1

Use a rectangle diagram.

Write $(-2g + 8)(7 - 3g)$ as $[(-2g) + 8][7 + (-3g)]$.

Draw a rectangle with dimensions $(-2g) + 8$ and $7 + (-3g)$.

Divide the rectangle into 4 smaller rectangles and label each one.

	7	$-3g$
$-2g$	$(-2g)(7) = -14g$	$(-2g)(-3g) = 6g^2$
8	$(8)(7) = 56$	$(8)(-3g) = -24g$

$$\begin{aligned} (-2g + 8)(7 - 3g) &= -14g + 6g^2 + 56 - 24g \\ &= 6g^2 - 14g - 24g + 56 \\ &= 6g^2 - 38g + 56 \end{aligned}$$

Method 2

Use the distributive property.

$$\begin{aligned} (-2g + 8)(7 - 3g) &= (-2g)(7 - 3g) + 8(7 - 3g) \\ &= -14g + 6g^2 + 56 - 24g \\ &= -38g + 6g^2 + 56 \\ &= 6g^2 - 38g + 56 \end{aligned}$$

CHECK YOUR UNDERSTANDING

2. Expand and simplify:

$$(6t - 9)(7 - 5t)$$

[Answer: $-30t^2 + 87t - 63$]

Which terms of the binomial factors determine the value of each term in the trinomial? How can you use this to simplify the calculation?

We can use algebra tiles to factor a trinomial when its terms are positive.

For example, to factor $2x^2 + 5x + 3$, arrange the tiles that represent these terms in a rectangle.

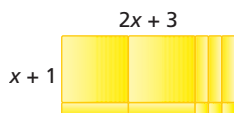

This algebra-tile model illustrates how the terms in the two binomial factors are related to the terms in the trinomial.

$$2x^2 + 5x + 3 = (2x + 3)(x + 1)$$

$2x^2$ is the product of the 1st terms in the binomials.

$$2x^2 + 5x + 3 = (2x + 3)(x + 1)$$

$5x$ is the sum of these products: $2x(1) + 3(x)$

$$2x^2 + 5x + 3 = (2x + 3)(x + 1)$$

3 is the product of the 2nd terms in the binomials.

When we use algebra tiles to factor a trinomial with negative terms, we may have to use the Zero Principle and add pairs of opposite tiles to form a rectangle. For example, to model the factoring of the trinomial $3x^2 + 5x - 2$, first arrange the tiles to attempt to form a rectangle. To complete the rectangle, we need two x -tiles. So, add one positive x -tile and one negative x -tile. Place them so that all the positive x -tiles are together.



$$\text{So, } 3x^2 + 5x - 2 = (3x - 1)(x + 2)$$

Some trinomials, for example $2x^2 + x + 1$, cannot be factored. You cannot add pairs of opposite x -tiles to form a rectangle.

What do you know about a polynomial for which you can never form a rectangle?

We can use the patterns on page 171 and logical reasoning to factor without algebra tiles. Often, by looking carefully at the relative sizes of the coefficients, we can estimate which factors of the coefficients of the trinomial to try first.

Example 3 Factoring a Trinomial Using Logical Reasoning

Factor.

a) $4h^2 + 20h + 9$ b) $6k^2 - 11k - 35$

SOLUTIONS

a) Method 1

$$4h^2 + 20h + 9$$

To factor this trinomial, find factors of the form $(ah + b)(ch + d)$.

The coefficient of h^2 is 4, so the coefficients of the 1st terms in the binomial are factors of 4, which are 1 and 4, or 2 and 2.

So, the binomials have the form

$$(h + b)(4h + d) \quad \text{or} \quad (2h + b)(2h + d)$$

The constant term in the trinomial is 9, so the 2nd terms in the binomial are factors of 9, which are 1 and 9, or 3 and 3.

So, the binomials could be:

$$(h + 1)(4h + 9) \quad \text{or} \quad (2h + 1)(2h + 9) \quad \text{or}$$

$$(h + 9)(4h + 1) \quad \text{or} \quad (2h + 9)(2h + 1) \quad \text{or}$$

$$(h + 3)(4h + 3) \quad \text{or} \quad (2h + 3)(2h + 3)$$

Check which of the 6 binomial products above has its h -term equal to $20h$.

$$(h + 1)(4h + 9) = 4h^2 + 13h + 9$$

$$(2h + 1)(2h + 9) = 4h^2 + 20h + 9$$

This is the correct trinomial so we need not check any further.

$$4h^2 + 20h + 9 = (2h + 1)(2h + 9)$$

(Solution continues.)

CHECK YOUR UNDERSTANDING

3. Factor.

a) $4g^2 + 11g + 6$

b) $6m^2 - 7m - 10$

[Answers: a) $(4g + 3)(g + 2)$

b) $(6m + 5)(m - 2)$]

In *Example 3a*, why did we not need to list or check the negative factors of 4?

Method 2

$$4h^2 + 20h + 9$$

Use number sense and reasoning, with mental math.

The factors of $4h^2$ are $4h$ and $1h$, or $2h$ and $2h$.

The factors of 9 are 9 and 1, or 3 and 3.

The coefficient of the middle term of the trinomial, 20, is greater than the coefficients of the other two terms, so try the greater factors. Arrange the factor combinations vertically.

$$\begin{array}{r} 4h \quad 9 \\ \times \\ 1h \quad 1 \end{array}$$

$$4h + 9h = 13h$$

$$\begin{array}{r} 2h \quad 9 \\ \times \\ 2h \quad 1 \end{array}$$

$$2h + 18h = 20h$$

Form the products,
then add.

← This is the correct
combination of factors.

$$\text{So, } 4h^2 + 20h + 9 = (2h + 9)(2h + 1)$$

b) Method 1

$$6k^2 - 11k - 35$$

Find factors of the form $(ak + b)(ck + d)$.

The coefficient of k^2 is 6, so the coefficients of the 1st terms in the binomial are factors of 6, which are 1 and 6, or 2 and 3.

The constant term in the trinomial is -35 , so the 2nd terms in the binomial are factors of -35 , which are 1 and -35 , or -1 and 35, or -5 and 7, or 5 and -7 .

The coefficient of the middle term of the trinomial, -11 , is between the coefficients of the other two terms, so try combinations of the lesser factors first; that is, try combinations of 2 and 3 with combinations of ± 5 and ± 7 .

So, the binomials could be:

$$\begin{array}{l} (2k + 5)(3k - 7) \quad \text{or} \quad (2k - 7)(3k + 5) \quad \text{or} \\ (2k - 5)(3k + 7) \quad \text{or} \quad (2k + 7)(3k - 5) \end{array}$$

Check if any of the 4 binomial products above has its k -term equal to $-11k$.

$$(2k + 5)(3k - 7) = 6k^2 + k - 35$$

$$(2k - 7)(3k + 5) = 6k^2 - 11k - 35$$

This is the correct trinomial so we need not check any further.

$$6k^2 - 11k - 35 = (2k - 7)(3k + 5)$$

(Solution continues.)

In Example 3b, why did we not need to list or check the negative factors of 6?

Method 2

$$6k^2 - 11k - 35$$

Use number sense and mental math, with guess and test.

The factors of $6k^2$ are $1k$ and $6k$, or $2k$ and $3k$.

The factors of -35 are 1 and -35 , or -1 and 35 , or -7 and 5 , or 7 and -5 .

The coefficient of the middle term of the trinomial, -11 , is between the coefficients of the other terms, so try factors of these coefficients that would be in the middle if the factors were listed in numerical order. Arrange the factor combinations vertically:

$$\begin{array}{r} 2k \quad 7 \\ \times \\ 3k \quad -5 \end{array}$$

$$-10k + 21k = 11k$$

$$6k^2 - 11k - 35 = (2k - 7)(3k + 5)$$

$$\begin{array}{r} 2k \quad -7 \\ \times \\ 3k \quad 5 \end{array}$$

$$10k - 21k = -11k$$

Form the products, then add.

← This is the correct combination of factors.

Factoring by decomposition

is factoring after writing the middle term of a trinomial as a sum of two terms, then determining a common binomial factor from the two pairs of terms formed.

Another method of factoring is **factoring by decomposition**.

Consider the binomial product: $(3h + 4)(2h + 1)$

We can use the distributive property to expand:

$$\begin{aligned} (3h + 4)(2h + 1) &= 3h(2h + 1) + 4(2h + 1) \\ &= 6h^2 + 3h + 8h + 4 \\ &= 6h^2 + 11h + 4 \end{aligned}$$

To factor $6h^2 + 11h + 4$ by decomposition, we reverse the steps above.

Notice that the coefficients of the h -terms have the product: $3(8) = 24$

This is equal to the product of the coefficient of the h^2 -term and the constant term: $6(4) = 24$

So, to factor $6h^2 + 11h + 4$, we *decompose* the h -term and write it as a sum of two terms whose coefficients have a product of 24.

Why don't we need to list the negative factors of 24?

Factors of 24	Sum of Factors
1, 24	$1 + 24 = 25$
2, 12	$2 + 12 = 14$
3, 8	$3 + 8 = 11$
4, 6	$4 + 6 = 10$

The two coefficients that have a sum of 11 are 3 and 8, so we write the trinomial $6h^2 + 11h + 4$ as $6h^2 + 3h + 8h + 4$.

We remove a common factor from the 1st pair of terms, and from the 2nd pair of terms:

$$6h^2 + 3h + 8h + 4 = 3h(2h + 1) + 4(2h + 1)$$

Each product has the common binomial factor $2h + 1$.

$$6h^2 + 11h + 4 = (2h + 1)(3h + 4)$$

Example 4 Factoring a Trinomial by Decomposition

Factor.

a) $3s^2 - 13s - 10$ b) $6x^2 - 21x + 9$

SOLUTION

a) $3s^2 - 13s - 10$

Check for common factors; there are none.

The product of the coefficient of s^2 and the constant term is: $3(-10) = -30$

Write $-13s$ as the sum of two terms whose coefficients have a product of -30 .

Factors of -30	Sum of Factors
1, -30	$1 - 30 = -29$
$-1, 30$	$-1 + 30 = 29$
2, -15	$2 - 15 = -13$
$-2, 15$	$-2 + 15 = 13$
3, -10	$3 - 10 = -7$
$-3, 10$	$-3 + 10 = 7$
5, -6	$5 - 6 = -1$
$-5, 6$	$-5 + 6 = 1$

The two coefficients are 2 and -15 , so write the trinomial $3s^2 - 13s - 10$ as $3s^2 + 2s - 15s - 10$.

Remove a common factor from the 1st pair of terms, and from the 2nd pair of terms:

$$3s^2 + 2s - 15s - 10 = s(3s + 2) - 5(3s + 2)$$

Each product has a common binomial factor.

$$3s^2 + 2s - 15s - 10 = (3s + 2)(s - 5)$$

$$\text{So, } 3s^2 - 13s - 10 = (3s + 2)(s - 5)$$

b) $6x^2 - 21x + 9$

Check for common factors; 3 is a common factor.

$$\text{So, } 6x^2 - 21x + 9 = 3(2x^2 - 7x + 3)$$

Factor $2x^2 - 7x + 3$.

(Solution continues.)

CHECK YOUR UNDERSTANDING

4. Factor.

a) $8p^2 - 18p - 5$

b) $24h^2 - 20h - 24$

[Answers: a) $(2p - 5)(4p + 1)$

b) $4(2h - 3)(3h + 2)$]

When we write the middle term as the sum of two terms, could we write $3s^2 - 15s + 2s - 10$ instead? Justify your answer.

The product of the coefficient of x^2 and the constant term is: $2(3) = 6$

Write $-7x$ as the sum of two terms whose coefficients have a product of 6.

Factors of 6	Sum of Factors
1, 6	$1 + 6 = 7$
-1, -6	$-1 - 6 = -7$
2, 3	$2 + 3 = 5$
-2, -3	$-2 - 3 = -5$

The two coefficients are -1 and -6 , so write the trinomial $2x^2 - 7x + 3$ as $2x^2 - 1x - 6x + 3$.

Remove a common factor from the 1st pair of terms, and from the 2nd pair of terms:

$$2x^2 - 1x - 6x + 3 = x(2x - 1) - 3(2x - 1)$$

Each product has a common binomial factor.

$$2x^2 - 1x - 6x + 3 = (2x - 1)(x - 3)$$

$$\text{So, } 2x^2 - 7x + 3 = (2x - 1)(x - 3)$$

$$\text{And, } 6x^2 - 21x + 9 = 3(2x - 1)(x - 3)$$

When would you use decomposition to factor a trinomial?

To check that the factors are correct, multiply them.

In *Example 4b*, multiply:

$$\begin{aligned} 3(2x - 1)(x - 3) &= 3(2x^2 - 6x - x + 3) \\ &= 3(2x^2 - 7x + 3) \\ &= 6x^2 - 21x + 9 \end{aligned}$$

Since this trinomial is the same as the original trinomial, the factors are correct.

Discuss the Ideas

1. How are the strategies for multiplying binomial factors of the form $(ax + b)(cx + d)$ like the strategies you used in Lesson 3.5 for products of the form $(x + a)(x + b)$? How are they different?
2. How can you use the coefficients of a trinomial to determine the coefficients of its binomial factors?
3. How can you tell when a trinomial cannot be factored?
4. How can you use logical reasoning to reduce the number of possible combinations of coefficients you have to consider in the guess-and-test or the decomposition methods of factoring a trinomial?

Exercises

A

5. Write the multiplication sentence that each set of algebra tiles represents.

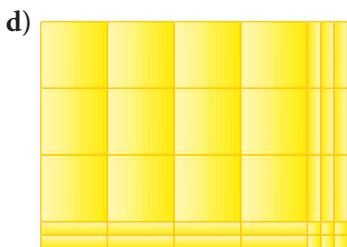
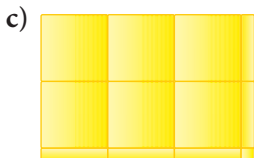
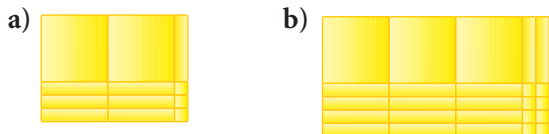

6. Use algebra tiles to determine each product.

- a) $(2v + 3)(v + 2)$ b) $(3r + 1)(r + 4)$
 c) $(2g + 3)(3g + 2)$ d) $(4z + 3)(2z + 5)$
 e) $(3t + 4)(3t + 4)$ f) $(2r + 3)(2r + 3)$

7. For each set of algebra tiles below:

- i) Write the trinomial that the algebra tiles represent.
 ii) Arrange the tiles to form a rectangle.
 Sketch the rectangle.
 iii) Use the rectangle to factor the trinomial.

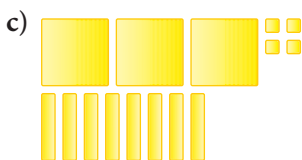
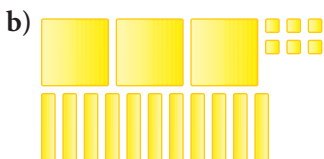

B

8. Copy and complete each statement.

- a) $(2w + 1)(w + 6) = 2w^2 + \square w + 6$
 b) $(2g - 5)(3g - 3) = 6g^2 + \square + \circ$
 c) $(-4v - 3)(-2v - 7) = \square + \circ + 21$

9. Expand and simplify.

- a) $(5 + f)(3 + 4f)$
 b) $(3 - 4t)(5 - 3t)$
 c) $(10 - r)(9 + 2r)$
 d) $(-6 + 2m)(-6 + 2m)$
 e) $(-8 - 2x)(3 - 7x)$
 f) $(6 - 5n)(-6 + 5n)$

10. Expand and simplify.

- a) $(3c + 4)(5 + 2c)$
 b) $(1 - 7t)(3t + 5)$
 c) $(-4r - 7)(2 - 8r)$
 d) $(-9 - t)(-5t - 1)$
 e) $(7h + 10)(-3 + 5h)$
 f) $(7 - 6y)(6y - 7)$

11. a) Use algebra tiles to factor each polynomial. Sketch the tiles you used.

- i) $3t^2 + 4t + 1$
 ii) $3t^2 + 8t + 4$
 iii) $3t^2 + 12t + 9$
 iv) $3t^2 + 16t + 16$

b) What patterns do you see in the algebra-tile rectangles? How are these patterns shown in the binomial factors?

c) Write the next 3 trinomials in the pattern and their binomial factors.

12. Factor. What patterns do you see in the trinomials and their factors?

- a) i) $2n^2 + 13n + 6$ ii) $2n^2 - 13n + 6$
 b) i) $2n^2 + 11n - 6$ ii) $2n^2 - 11n - 6$
 c) i) $2n^2 + 7n + 6$ ii) $2n^2 - 7n + 6$

13. Factor. Check by expanding.

- a) $2y^2 + 5y + 2$ b) $2a^2 + 11a + 12$
 c) $2k^2 + 13k + 15$ d) $2m^2 - 11m + 12$
 e) $2k^2 - 11k + 15$ f) $2m^2 + 15m + 7$
 g) $2g^2 + 15g + 18$ h) $2n^2 + 9n - 18$

14. a) Find two integers with the given properties.

	Product	Sum
i)	15	16
ii)	24	14
iii)	15	8
iv)	12	7
v)	12	13
vi)	24	11

- b) Use the results of part a to use decomposition to factor each trinomial.
- i) $3v^2 + 16v + 5$ ii) $3m^2 + 14m + 8$
 iii) $3b^2 + 8b + 5$ iv) $4a^2 + 7a + 3$
 v) $4d^2 + 13d + 3$ vi) $4v^2 + 11v + 6$

15. Factor. Check by expanding.

- a) $5a^2 - 7a - 6$ b) $3y^2 - 13y - 10$
 c) $5s^2 + 19s - 4$ d) $14c^2 - 19c - 3$
 e) $8a^2 + 18a - 5$ f) $8r^2 - 14r + 3$
 g) $6d^2 + d - 5$ h) $15e^2 - 7e - 2$

16. Find and correct the errors in each factorization.

- a) $6u^2 + 17u - 14 = (2u - 7)(3u + 2)$
 b) $3k^2 - k - 30 = (3k - 3)(k + 10)$
 c) $4v^2 - 21v + 20 = (4v - 4)(v + 5)$

17. Find and correct the errors in this solution of factoring by decomposition.

$$\begin{aligned} 15g^2 + 17g - 42 &= 15g^2 - 18g + 35g - 42 \\ &= 3g(5g - 6) + 7(5g + 6) \\ &= (3g + 7)(5g + 6) \end{aligned}$$

18. Factor.

- a) $20r^2 + 70r + 60$ b) $15a^2 - 65a + 20$
 c) $18h^2 + 15h - 18$ d) $24u^2 - 72u + 54$
 e) $12m^2 - 52m - 40$ f) $24g^2 - 2g - 70$

19. Factor.

- a) $14y^2 - 13y + 3$ b) $10p^2 - 17p - 6$
 c) $10r^2 - 33r - 7$ d) $15g^2 - g - 2$
 e) $4x^2 + 4x - 15$ f) $9d^2 - 24d + 16$
 g) $9t^2 + 12t + 4$ h) $40y^2 + y - 6$
 i) $24c^2 + 26c - 15$ j) $8x^2 + 14x - 15$

20. Find an integer to replace \square so that each trinomial can be factored.

How many integers can you find each time?

- a) $4s^2 + \square s + 3$ b) $4h^2 + \square h + 25$
 c) $6y^2 + \square y - 9$ d) $12t^2 + \square t + 10$
 e) $9z^2 + \square z + 1$ f) $\square f^2 + 2f + \square$

C

21. a) Factor, if possible.

- i) $4r^2 - r - 5$ ii) $2t^2 + 10t + 3$
 iii) $5y^2 + 4y - 2$ iv) $2w^2 - 5w + 2$
 v) $3h^2 - 8h - 3$ vi) $2f^2 - f + 1$

- b) Choose two trinomials from part a: one that can be factored and one that cannot be factored. Explain why the first trinomial can be factored and the second one cannot be factored.

22. a) Factor each trinomial.

- i) $3n^2 + 11n + 10$ ii) $3n^2 - 11n + 10$
 iii) $3n^2 + 13n + 10$ iv) $3n^2 - 13n + 10$
 v) $3n^2 + 17n + 10$ vi) $3n^2 - 17n + 10$

- b) Look at the trinomials and their factors in part a. Are there any other trinomials that begin with $3n^2$, end with $+10$, and can be factored? Explain.

23. Find all the trinomials that begin with $9m^2$, end with $+16$, and can be factored.

Reflect

Which strategies can you use to factor a trinomial? Give an example of when you might use each strategy to factor a trinomial.

CHECKPOINT 2

Connections

Type of Factor	Patterns Relating Factors and the Product	Example
Monomial \times Polynomial	The monomial factor is the greatest common factor of the terms of the product polynomial.	$5x^2 - 10xy + 15x$ $= 5x(x - 2y + 3)$
$(x + a)(x + b)$	$(x + a)(x + b)$ $= x^2 + (a + b)x + ab$	$(x + 2)(x - 8)$ $= x^2 + 2x - 8x - 16$ $= x^2 - 6x - 16$
$(ax + b)(cx + d)$	$(ax + b)(cx + d)$ $= (ac)x^2 + (ad + bc)x + bd$	$(3x - 2)(2x + 5)$ $= 6x^2 - 4x + 15x - 10$ $= 6x^2 + 11x - 10$

Concept Development

In Lesson 3.3

- You applied an area model for the product of whole numbers to develop models and strategies to determine **common factors** in the terms of a polynomial.

In Lesson 3.4

- You used algebra tiles to **multiply binomials** and to **factor trinomials**.

In Lesson 3.5

- You used diagrams and algebraic strategies to **multiply binomials** and to **factor trinomials** of the form $x^2 + bx + c$.

In Lesson 3.6

- You extended the strategies from Lesson 3.5 to **multiply binomials** and to **factor trinomials** of the form $ax^2 + bx + c$.



THE WORLD OF MATH

Careers: Computer Graphics Artist

If you have played a video game or been to a movie recently, you may have seen special effects created by a computer graphics artist. To create an image in virtual space, the artist may take measurements from a model and make many calculations to ensure the objects look and move realistically on the screen. Computer graphics artists use their knowledge of algebra and geometry to help produce visually attractive and entertaining material.



Assess Your Understanding

3.3

1. For each set of algebra tiles, write the polynomial they represent and identify its factors. Sketch the tile arrangement that illustrates the factors.



2. a) Factor each polynomial. Use algebra tiles when you can. Sketch the tiles you used.

i) $4a + 8$

ii) $3c - 6$

iii) $-2v^2 - 5v$

iv) $2x^2 + 14x + 6$

v) $-3r^2 + 15r - 3$

vi) $15a^3 - 3a^2b - 6ab^2$

vii) $12 - 32x + 8x^2$

viii) $12x^2y - 8xy - 16y$

- b) For which polynomials in part a could you not use algebra tiles? Explain why you could not use them.

3.4

3. Use 1 x^2 -tile. Choose x -tiles and 1-tiles to make a rectangle. Sketch your arrangement and write the multiplication sentence it represents.
4. Use 2 or more x^2 -tiles. Choose x -tiles and 1-tiles to make a rectangle. Sketch your arrangement and write the multiplication sentence it represents.

3.5

5. Expand and simplify. Use an area model or a rectangle diagram to illustrate each product.

a) $(x + 1)(x + 4)$

b) $(d - 2)(d + 3)$

c) $(x - 4)(x - 2)$

d) $(5 - r)(6 + r)$

e) $(g + 5)(g - 1)$

f) $(2 - t)(10 - t)$

6. Factor each trinomial. Check by expanding.

a) $s^2 + 11s + 30$

b) $n^2 - n - 30$

c) $20 - 9b + b^2$

d) $-11 - 10t + t^2$

e) $z^2 + 13z + 30$

f) $-k^2 + 9k - 18$

7. Factor.

a) $3x^2 + 15x - 42$

b) $-2y^2 + 22y - 48$

c) $-24 - 11m - m^2$

d) $50 - 23y - y^2$

3.6

8. Expand and simplify.

a) $(2c + 1)(c + 3)$

c) $(3f - 4)(3f + 1)$

e) $(5 - 3r)(6 + 2r)$

b) $(-m + 5)(4m - 1)$

d) $(6z - 1)(2z - 3)$

f) $(-4 - 2h)(-2 - 4h)$

9. Factor each trinomial. Check by expanding.

a) $2j^2 + 13j + 20$

c) $5k^2 - 23k + 12$

e) $8y^2 - 2y - 1$

b) $3v^2 + v - 10$

d) $9h^2 + 18h + 8$

f) $6 - 23u + 20u^2$



THE WORLD OF MATH

Historical Moment: François Viète

François Viète (1540–1603) was a lawyer who worked at the court of Henri III and Henri IV of France. In addition to offering legal advice, he was a cryptanalyst, deciphering messages intercepted between enemies of the king, but his hobby was mathematics. He was one of the first people to use letters to represent numbers. In his work *Prior Notes on Symbolic Logistic*, written toward the end of the sixteenth century but not published until 1631, he showed how to operate on symbolic quantities and derived many algebraic results. He applied his algebra to many different fields of mathematics, publishing work on trigonometry and what he viewed as his most elegant, the analysis of equations.



3.7 Multiplying Polynomials

LESSON FOCUS

Extend the strategies for multiplying binomials to multiplying polynomials.

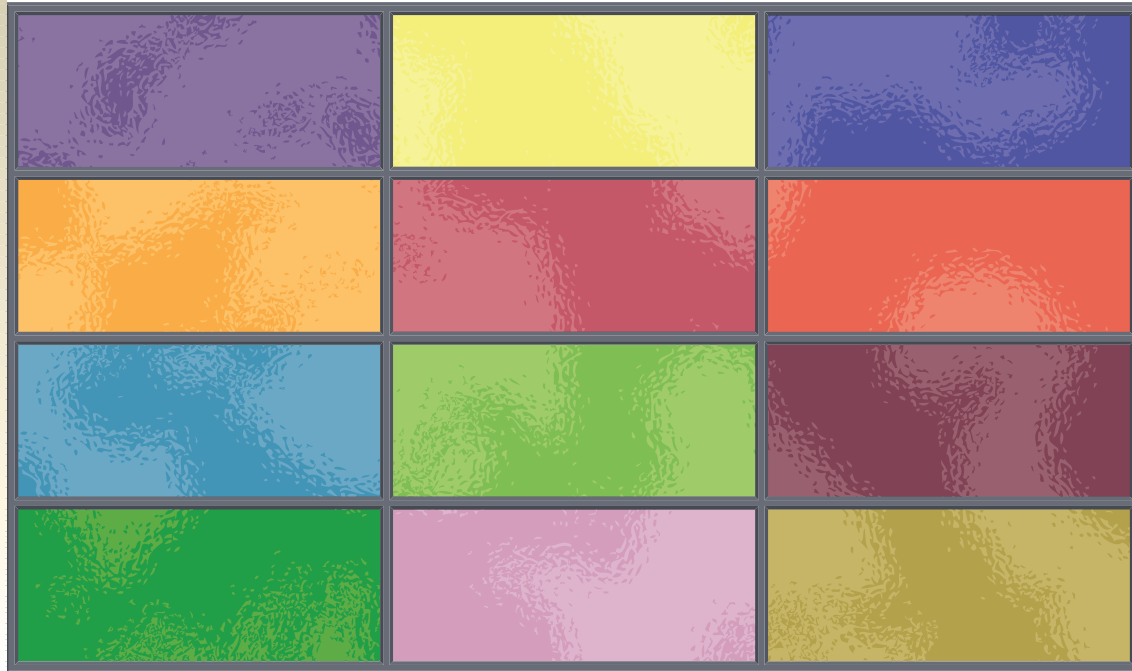

Make Connections

The art work above was a design for a stained glass panel. How could you use the length and width of each small rectangle to determine the area of the large rectangle without first finding its overall length and width?

Construct Understanding

THINK ABOUT IT

Work with a partner.

- Draw a rectangle diagram to determine the product $(a + b + 2)(c + d + 3)$.
- Draw a rectangle diagram to determine the product $(a - b + 2)(c + d - 3)$.
- Use a different strategy to check the products.

Would the product have been different if you reversed the order of the factors? Explain.

The distributive property can be used to perform any polynomial multiplication. Each term of one polynomial must be multiplied by each term of the other polynomial.

Example 1 Using the Distributive Property to Multiply Two Polynomials

Expand and simplify.

a) $(2h + 5)(h^2 + 3h - 4)$ b) $(-3f^2 + 3f - 2)(4f^2 - f - 6)$

SOLUTION

a) Use the distributive property. Multiply each term in the trinomial by each term in the binomial.

Write the terms in a list.

$$\begin{aligned} & (2h + 5)(h^2 + 3h - 4) \\ &= (2h)(h^2 + 3h - 4) + 5(h^2 + 3h - 4) \\ &= (2h)(h^2) + (2h)(3h) + 2h(-4) + 5(h^2) + 5(3h) + 5(-4) \\ &= 2h^3 + 6h^2 - 8h + 5h^2 + 15h - 20 \\ &= 2h^3 + 6h^2 + 5h^2 - 8h + 15h - 20 \quad \text{Combine like terms.} \\ &= 2h^3 + 11h^2 + 7h - 20 \end{aligned}$$

b) Use the distributive property. Multiply each term in the 1st trinomial by each term in the 2nd trinomial.

Align like terms.

$$\begin{array}{r} (-3f^2 + 3f - 2)(4f^2 - f - 6): \\ -3f^2(4f^2 - f - 6): \quad -12f^4 \quad + 3f^3 + 18f^2 \\ 3f(4f^2 - f - 6): \quad \quad \quad 12f^3 - 3f^2 - 18f \\ -2(4f^2 - f - 6): \quad \quad \quad \quad \quad -8f^2 + 2f + 12 \\ \hline \text{Add:} \quad \quad \quad -12f^4 + 15f^3 + 7f^2 - 16f + 12 \end{array}$$

CHECK YOUR UNDERSTANDING

1. Expand and simplify.

a) $(3k + 4)(k^2 - 2k - 7)$

b) $(-2t^2 + 4t - 3)(5t^2 - 2t + 1)$

[Answers: a) $3k^3 - 2k^2 - 29k - 28$

b) $-10t^4 + 24t^3 - 25t^2 + 10t - 3$]

Both solutions to parts a and b use the distributive property. Which strategy for recording the products of terms do you prefer, and why?

One way to check that a product is likely correct is to substitute a number for the variable in both the trinomial product and its simplification. If both expressions are equal, the product is likely correct.

In *Example 1a*, substitute $h = 1$.

$$(2h + 5)(h^2 + 3h - 4) = 2h^3 + 11h^2 + 7h - 20$$

$$\begin{aligned} \text{Left side: } (2h + 5)(h^2 + 3h - 4) &= [2(1) + 5][(1)^2 + 3(1) - 4] \\ &= (7)(0) \\ &= 0 \end{aligned}$$

$$\begin{aligned} \text{Right side: } 2h^3 + 11h^2 + 7h - 20 &= 2(1)^3 + 11(1)^2 + 7(1) - 20 \\ &= 2 + 11 + 7 - 20 \\ &= 0 \end{aligned}$$

Since the left side equals the right side, the product is likely correct.

In *Example 1b*, substitute $f = 1$.

$$(-3f^2 + 3f - 2)(4f^2 - f - 6) = -12f^4 + 15f^3 + 7f^2 - 16f + 12$$

$$\text{Left side: } (-3f^2 + 3f - 2)(4f^2 - f - 6)$$

$$= [(-3)(1)^2 + 3(1) - 2][(4(1)^2 - (1) - 6)]$$

$$= (-2)(-3)$$

$$= 6$$

$$\text{Right side: } -12f^4 + 15f^3 + 7f^2 - 16f + 12$$

$$= -12(1)^4 + 15(1)^3 + 7(1)^2 - 16(1) + 12$$

$$= -12 + 15 + 7 - 16 + 12$$

$$= 6$$

Since the left side equals the right side, the product is likely correct.

Example 2 Multiplying Polynomials in More than One Variable

Expand and simplify.

a) $(2r + 5t)^2$ b) $(3x - 2y)(4x - 3y + 5)$

SOLUTION

a) $(2r + 5t)^2 = (2r + 5t)(2r + 5t)$

$$= 2r(2r + 5t) + 5t(2r + 5t)$$

$$= 2r(2r) + 2r(5t) + 5t(2r) + 5t(5t)$$

$$= 4r^2 + 10rt + 10rt + 25t^2 \quad \text{Combine like terms.}$$

$$= 4r^2 + 20rt + 25t^2$$

b) $(3x - 2y)(4x - 3y + 5)$

$$= 3x(4x - 3y - 5) - 2y(4x - 3y + 5)$$

$$= 3x(4x) + 3x(-3y) + 3x(-5) - 2y(4x) - 2y(-3y) - 2y(5)$$

$$= 12x^2 - 9xy - 15x - 8xy + 6y^2 - 10y \quad \text{Collect like terms.}$$

$$= 12x^2 - 9xy - 8xy - 15x + 6y^2 - 10y \quad \text{Combine like terms.}$$

$$= 12x^2 - 17xy - 15x + 6y^2 - 10y$$

CHECK YOUR UNDERSTANDING

2. Expand and simplify.

a) $(4k - 3m)^2$

b) $(2v - 5w)(3v + 2w - 7)$

[Answers: a) $16k^2 - 24km + 9m^2$

b) $6v^2 - 11vw - 14v - 10w^2 + 35w$]

Look at the factors and product in part a. How could you write the product without using the distributive property?

Example 3 Simplifying Sums and Differences of Polynomial Products

Expand and simplify.

a) $(2c - 3)(c + 5) + 3(c - 3)(-3c + 1)$

b) $(3x + y - 1)(2x - 4) - (3x + 2y)^2$

SOLUTION

Use the order of operations. Multiply before adding and subtracting. Then combine like terms.

a) $(2c - 3)(c + 5) + 3(c - 3)(-3c + 1)$
 $= 2c(c + 5) - 3(c + 5) + 3[c(-3c + 1) - 3(-3c + 1)]$
 $= 2c^2 + 10c - 3c - 15 + 3[-3c^2 + c + 9c - 3]$
 $= 2c^2 + 7c - 15 + 3[-3c^2 + 10c - 3]$
 $= 2c^2 + 7c - 15 - 9c^2 + 30c - 9$
 $= -7c^2 + 37c - 24$

b) $(3x + y - 1)(2x - 4) - (3x + 2y)^2$
 $= 3x(2x - 4) + y(2x - 4) - 1(2x - 4) - (3x + 2y)(3x + 2y)$
 $= 6x^2 - 12x + 2xy - 4y - 2x + 4 - [3x(3x + 2y) + 2y(3x + 2y)]$
 $= 6x^2 - 14x + 2xy - 4y + 4 - [9x^2 + 6xy + 6xy + 4y^2]$
 $= 6x^2 - 14x + 2xy - 4y + 4 - [9x^2 + 12xy + 4y^2]$
 $= 6x^2 - 14x + 2xy - 4y + 4 - 9x^2 - 12xy - 4y^2$
 $= -3x^2 - 14x - 10xy - 4y + 4 - 4y^2$

CHECK YOUR UNDERSTANDING

3. Expand and simplify.

a) $(4m + 1)(3m - 2)$
 $+ 2(2m - 1)(-3m + 4)$

b) $(6h + k - 2)(2h - 3)$
 $- (4h - 3k)^2$

[Answers: a) $17m - 10$
b) $-4h^2 - 22h + 26hk - 3k + 6 - 9k^2$]

Discuss the Ideas

1. How is the process for multiplying polynomials with more than 2 terms like multiplying binomials? How is it different?
2. What strategies can you use to check that you have correctly multiplied two polynomials?
3. When you substitute a number for a variable to check that a polynomial product is correct, would 0 be a suitable number to substitute? Would 9 be a suitable number? Explain.

Exercises

A

4. Expand and simplify.
- $(g + 1)(g^2 + 2g + 3)$
 - $(2 + t + t^2)(1 + 3t + t^2)$
 - $(2w + 3)(w^2 + 4w + 7)$
 - $(4 + 3n + n^2)(3 + 5n + n^2)$
5. Expand and simplify.
- $(2z + y)(3z + y)$
 - $(4f - 3g)(3f - 4g + 1)$
 - $(2a + 3b)(4a + 5b)$
 - $(3a - 4b + 1)(4a - 5b)$
 - $(2r + s)^2$
 - $(3t - 2u)^2$

B

6. a) Expand and simplify.
- $(2x + y)(2x + y)$
 - $(5r + 2s)(5r + 2s)$
 - $(6c + 5d)(6c + 5d)$
 - $(5v + 7w)(5v + 7w)$
 - $(2x - y)(2x - y)$
 - $(5r - 2s)(5r - 2s)$
 - $(6c - 5d)(6c - 5d)$
 - $(5v - 7w)(5v - 7w)$
- b) What patterns do you see in the factors and products in part a? Use these patterns to expand and simplify each product without using the distributive property.
- $(p + 3q)(p + 3q)$
 - $(2s - 7t)(2s - 7t)$
 - $(5g + 4h)(5g + 4h)$
 - $(10h - 7k)(10h - 7k)$
7. a) Expand and simplify.
- $(x + 2y)(x - 2y)$
 - $(3r - 4s)(3r + 4s)$
 - $(5c + 3d)(5c - 3d)$
 - $(2v - 7w)(2v + 7w)$
- b) What patterns do you see in the factors and products in part a? Use these patterns to expand and simplify each product without using the distributive property.
- $(11g + 5h)(11g - 5h)$
 - $(25m - 7n)(25m + 7n)$
8. Expand and simplify.
- $(3y - 2)(y^2 + y - 8)$
 - $(4r + 1)(r^2 - 2r - 3)$
 - $(b^2 + 9b - 2)(2b - 1)$
 - $(x^2 + 6x + 1)(3x - 7)$
9. Expand and simplify.
- $(x + y)(x + y + 3)$
 - $(x + 2)(x + y + 1)$
 - $(a + b)(a + b + c)$
 - $(3 + t)(2 + t + s)$
10. Expand and simplify.
- $(x + 2y)(x - 2y - 1)$
 - $(2c - 3d)(c + d + 1)$
 - $(a - 5b)(a + 2b - 4)$
 - $(p - 2q)(p + 4q - r)$
11. Find and correct the errors in this solution.
- $$\begin{aligned}(2r - 3s)(r - 5s + 6) &= 2r(r - 5s + 6) - 3s(r - 5s + 6) \\ &= 2r^2 - 5rs + 12r - 3rs - 15s^2 - 18s \\ &= 2r^2 - 8rs + 12r - 33s^2\end{aligned}$$
12. The area of the base of a right rectangular prism is $x^2 + 3x + 2$. The height of the prism is $x + 7$. Write, then simplify an expression for the volume of the prism.
13. Expand and simplify. Substitute a number for the variable to check each product.
- $(r^2 + 3r + 2)(4r^2 + r + 1)$
 - $(2d^2 + 2d + 1)(d^2 + 6d + 3)$
 - $(4c^2 - 2c - 3)(-c^2 + 6c + 2)$
 - $(-4n^2 - n + 3)(-2n^2 + 5n - 1)$
14. Find and correct the errors in this solution.
- $$\begin{aligned}(3g^2 + 4g - 2)(-g^2 - g + 4) &= -3g^4 - 3g^3 + 12g^2 - 4g^3 + 4g^2 + 8g \\ &\quad + 2g^2 + 2g + 8 \\ &= -3g^4 + 5g^3 + 6g^2 + 10g + 8\end{aligned}$$
15. Expand and simplify.
- $(3s + 5)(2s + 2) + (3s + 7)(s + 6)$
 - $(2x + 3)(5x + 4) + (x - 4)(3x - 7)$
 - $(3m + 4)(m - 4n) + (5m - 2)(3m - 6n)$
 - $(4y - 5)(3y + 2) - (3y + 2)(4y - 5)$
 - $(3x - 2)^2 - (2x + 6)(3x - 1)$
 - $(2a + 1)(4a - 3) - (a - 2)^2$

16. A box with no top is made from a piece of cardboard 20 cm by 10 cm. Equal squares are cut from each corner and the sides are folded up.

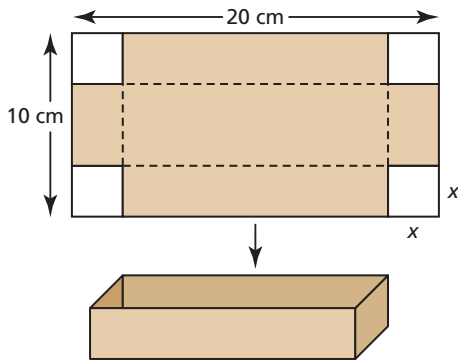

Let x centimetres represent the side length of each square cut out. Write a polynomial to represent each measurement. Simplify each polynomial.

- the length of the box
 - the width of the box
 - the area of the base of the box
 - the volume of the box
17. Each shape is a rectangle. Write a polynomial to represent the area of each shaded region. Simplify each polynomial.

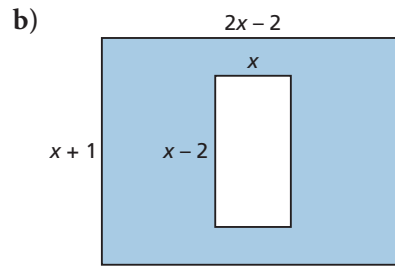
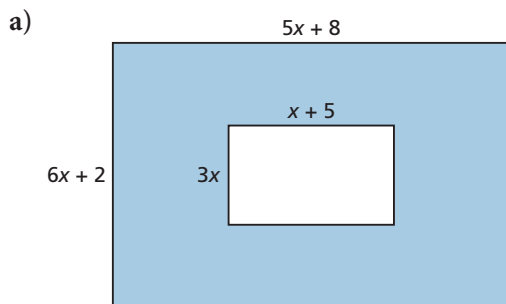

C

18. Expand and simplify.
- $(x - 2)^3$
 - $(2y + 5)^3$
 - $(4a - 3b)^3$
 - $(c + d)^3$
19. Expand and simplify.
- $2a(2a - 1)(3a + 2)$
 - $-3r(r - 1)(2r + 1)$
 - $5x^2(2x - 1)(4x - 3)$
 - $-xy(2x + 5)(4x - 5)$
 - $2b(2b - c)(b + c)$
 - $y^2(y^2 + 1)(y^2 - 1)$
20. A cube has edge length $2x + 3$.
- Write then simplify an expression for the volume of the cube.
 - Write then simplify an expression for the surface area of the cube.
21. Expand and simplify.
- $(3x + 4)(x - 5)(2x + 8)$
 - $(b - 7)(b + 8)(3b - 4)$
 - $(2x - 5)(3x + 4)^2$
 - $(5a - 3)^2(2a - 7)$
 - $(2k - 3)(2k + 3)^2$
22. Expand and simplify.
- $(x + y + 1)^3$
 - $(x - y - 1)^3$
 - $(x + y + z)^3$
 - $(x - y - z)^3$

Reflect

What strategies do you know for multiplying two binomials? How can you use or adapt those strategies to multiply two trinomials? Include examples in your explanation.

3.8 Factoring Special Polynomials

LESSON FOCUS

Investigate some special factoring patterns.



Make Connections

The area of a square plot of land is one hectare (1 ha).

$$1 \text{ ha} = 10\,000 \text{ m}^2$$

So, one side of the plot has length $\sqrt{10\,000} \text{ m} = 100 \text{ m}$

Suppose the side length of the plot of land is increased by x metres.
What binomial represents the side length of the plot in metres?
What trinomial represents the area of the plot in square metres?

Construct Understanding

THINK ABOUT IT

Work with a partner.

You may need algebra tiles.

- Determine each product.

$$(x + 1)^2$$

$$(x + 2)^2$$

$$(x + 3)^2$$

$$(x - 1)^2$$

$$(x - 2)^2$$

$$(x - 3)^2$$

$$(2x + 1)^2$$

$$(3x + 1)^2$$

$$(4x + 1)^2$$

$$(2x - 1)^2$$

$$(3x - 1)^2$$

$$(4x - 1)^2$$

- What patterns do you see in the trinomials and their factors above?
How could you use the patterns to factor these trinomials?
 $4x^2 + 20x + 25$ $9x^2 - 12x + 4$
- Write two more polynomials that have the same pattern,
then factor the polynomials.
Write a strategy for factoring polynomials of this type.

Here is a square with side length $a + b$:

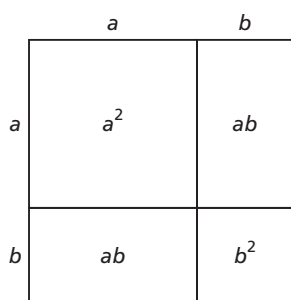

$$\begin{aligned}
 \text{Its area is: } (a + b)^2 &= (a + b)(a + b) \\
 &= a(a + b) + b(a + b) \\
 &= a^2 + ab + ab + b^2 \\
 &= a^2 + 2ab + b^2
 \end{aligned}$$

We say that $a^2 + 2ab + b^2$ is a **perfect square trinomial**.

$$\begin{array}{l}
 \text{The square of the 1st term in the binomial} \\
 \downarrow \\
 \text{Twice the product of the first and second terms in the binomial} \\
 \downarrow \\
 \text{The square of the 2nd term in the binomial} \\
 \downarrow \\
 (a + b)^2 = a^2 + 2ab + b^2
 \end{array}$$

Perfect Square Trinomial

The area model of a perfect square trinomial results in a square.

In factored form, a perfect square trinomial is:

$$a^2 + 2ab + b^2 = (a + b)(a + b), \text{ or } (a + b)^2$$

$$\text{And, } a^2 - 2ab + b^2 = (a - b)(a - b), \text{ or } (a - b)^2$$

We can use these patterns to factor perfect square trinomials.

Example 1 Factoring a Perfect Square Trinomial

Factor each trinomial. Verify by multiplying the factors.

a) $4x^2 + 12x + 9$ b) $4 - 20x + 25x^2$

SOLUTION

a) $4x^2 + 12x + 9$

Arrange algebra tiles to form a rectangle.

The rectangle is a square with side length $2x + 3$.

$$4x^2 + 12x + 9 = (2x + 3)^2$$

To verify, multiply:

$$\begin{aligned}(2x + 3)(2x + 3) &= 2x(2x + 3) + 3(2x + 3) \\ &= 4x^2 + 6x + 6x + 9 \\ &= 4x^2 + 12x + 9\end{aligned}$$

Since this trinomial is the same as the original trinomial, the factors are correct.

b) $4 - 20x + 25x^2$

The 1st term is a perfect square since $4 = (2)(2)$

The 3rd term is a perfect square since $25x^2 = (5x)(5x)$

The 2nd term is twice the product of $5x$ and 2 :

$$20x = 2(5x)(2)$$

Since the 2nd term is negative, the operations in the binomial factors must be subtraction.

So, the trinomial is a perfect square and its factors are:

$$(2 - 5x)(2 - 5x), \text{ or } (2 - 5x)^2$$

$$\begin{aligned}\text{To verify, multiply: } (2 - 5x)(2 - 5x) &= 2(2 - 5x) - 5x(2 - 5x) \\ &= 4 - 10x - 10x + 25x^2 \\ &= 4 - 20x + 25x^2\end{aligned}$$

Since this trinomial is the same as the original trinomial, the factors are correct.

CHECK YOUR UNDERSTANDING

1. Factor each trinomial. Verify by multiplying the factors.

a) $36x^2 + 12x + 1$

b) $16 - 56x + 49x^2$

[Answers: a) $(6x + 1)^2$
b) $(4 - 7x)^2$]

When $ax^2 + bx + c$ is a perfect square trinomial, how are a , b , and c related?

In Lesson 3.7, you multiplied two binomials in two variables. We can use the inverse process to factor trinomials of this form. We can use the strategy of logical reasoning or decomposition.

Example 2 Factoring Trinomials in Two Variables

Factor each trinomial. Verify by multiplying the factors.

a) $2a^2 - 7ab + 3b^2$ b) $10c^2 - cd - 2d^2$

SOLUTION

a) $2a^2 - 7ab + 3b^2$

Use logical reasoning. Since the 3rd term in the trinomial is positive, the operations in the binomial factors will be the same. Since the 2nd term is negative, these operations will be subtraction.

The two binomials will have the form: $(?a - ?b)(?a - ?b)$

List the possible factors of $2a^2$ and $3b^2$, then use guess and test to determine which combination of products has the sum of $-7ab$.

$$\begin{array}{r} 1a \quad -1b \\ \diagdown \quad \diagup \\ 2a \quad -3b \end{array}$$

$$\begin{array}{r} 1a \quad -3b \\ \diagdown \quad \diagup \\ 2a \quad -1b \end{array}$$

Form the products,
then add.

$$-3ab - 2ab = -5ab \quad -1ab - 6ab = -7ab \leftarrow \text{This is the correct combination of factors.}$$

$$\text{So, } 2a^2 - 7ab + 3b^2 = (2a - b)(a - 3b)$$

To verify, multiply:

$$\begin{aligned} (2a - b)(a - 3b) &= 2a(a - 3b) - b(a - 3b) \\ &= 2a^2 - 6ab - ab + 3b^2 \\ &= 2a^2 - 7ab + 3b^2 \end{aligned}$$

Since this trinomial is the same as the original trinomial, the factors are correct.

b) $10c^2 - cd - 2d^2$

Use decomposition. Since the 3rd term in the trinomial is negative, the operations in the binomial factors will be addition and subtraction.

The two binomials will have the form: $(?c + ?d)(?c - ?d)$

The product of the coefficients of c^2 and d^2 is: $10(-2) = -20$

Write $-1cd$ as a sum of two terms whose coefficients have a product of -20 .

(Solution continues.)

CHECK YOUR UNDERSTANDING

2. Factor each trinomial. Verify by multiplying the factors.

a) $5c^2 - 13cd + 6d^2$

b) $3p^2 - 5pq - 2q^2$

[Answers: a) $(5c - 3d)(c - 2d)$

b) $(3p + q)(p - 2q)$]

Factors of -20	Sum of Factors
1, -20	$1 - 20 = -19$
$-1, 20$	$-1 + 20 = 19$
2, -10	$2 - 10 = -8$
$-2, 10$	$-2 + 10 = 8$
4, -5	$4 - 5 = -1$
$-4, 5$	$-4 + 5 = 1$

The two coefficients are 4 and -5 , so write the trinomial $10c^2 - cd - 2d^2$ as $10c^2 + 4cd - 5cd - 2d^2$.

Remove a common factor from the 1st pair of terms, and from the 2nd pair of terms:

$$10c^2 + 4cd - 5cd - 2d^2 = 2c(5c + 2d) - d(5c + 2d)$$

Remove the common binomial factor.

$$\text{So, } 10c^2 - cd - 2d^2 = (5c + 2d)(2c - d)$$

To verify, multiply:

$$\begin{aligned} (5c + 2d)(2c - d) &= 5c(2c - d) + 2d(2c - d) \\ &= 10c^2 - 5cd + 4cd - 2d^2 \\ &= 10c^2 - cd - 2d^2 \end{aligned}$$

Since this trinomial is the same as the original trinomial, the factors are correct.

Another example of a special polynomial is a **difference of squares**.

A difference of squares is a binomial of the form $a^2 - b^2$.

We can think of it as a trinomial with a middle term of 0.

That is, write $a^2 - b^2$ as $a^2 + 0ab - b^2$.

Consider the binomial $x^2 - 25$.

This is a difference of squares because $x^2 = (x)(x)$ and $25 = (5)(5)$.

We write $x^2 - 25$ as $x^2 - 0x - 25$.

To factor this trinomial, look for 2 integers whose product is -25 and whose sum is 0.

The two integers are 5 and -5 .

$$\text{So, } x^2 - 25 = (x + 5)(x - 5)$$

This pattern is true for the difference of any two squares.

Difference of Squares

A difference of squares has the form $a^2 - b^2$.

In factored form, $a^2 - b^2 = (a - b)(a + b)$

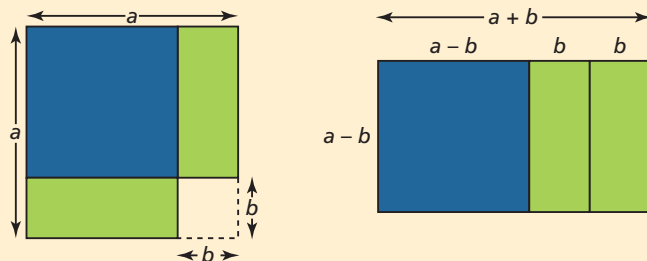

Example 3 Factoring a Difference of Squares

Factor each binomial.

a) $25 - 36x^2$ b) $5x^4 - 80y^4$

SOLUTION

a) $25 - 36x^2$

Write each term as a perfect square.

$$\begin{aligned} 25 - 36x^2 &= (5)^2 - (6x)^2 && \text{Write these terms in} \\ & && \text{binomial factors.} \\ &= (5 + 6x)(5 - 6x) \end{aligned}$$

b) $5x^4 - 80y^4$

As written, each term of the binomial is not a perfect square. But the terms have a common factor 5. Remove this common factor.

$$\begin{aligned} 5x^4 - 80y^4 & && \text{Now write each term in the} \\ &= 5(x^4 - 16y^4) && \text{binomial as a perfect square.} \end{aligned}$$

$$= 5[(x^2)^2 - (4y^2)^2] \quad \text{Write these terms in binomial factors.}$$

$$= 5(x^2 - 4y^2)(x^2 + 4y^2) \quad \text{The 1st binomial is also a difference of squares.}$$

$$= 5(x + 2y)(x - 2y)(x^2 + 4y^2)$$

CHECK YOUR UNDERSTANDING

3. Factor each binomial.

a) $81m^2 - 49$

b) $162v^4 - 2w^4$

[Answers: a) $(9m - 7)(9m + 7)$
b) $2(3v - w)(3v + w)(9v^2 + w^2)$]

Does a sum of squares factor? Explain.

Discuss the Ideas

- How do the area models and rectangle diagrams support the naming of a perfect square trinomial and a difference of squares binomial?
- Why is it useful to identify the factoring patterns for perfect square trinomials and difference of squares binomials?
- Why can you use the factors of a trinomial in one variable to factor a corresponding trinomial in two variables?

Exercises

A

- Expand and simplify.

a) $(x + 2)^2$	b) $(3 - y)^2$
c) $(5 + d)^2$	d) $(7 - f)^2$
e) $(x + 2)(x - 2)$	f) $(3 - y)(3 + y)$
g) $(5 + d)(5 - d)$	h) $(7 - f)(7 + f)$
- Identify each polynomial as a perfect square trinomial, a difference of squares, or neither.

a) $25 - t^2$
b) $16m^2 + 49n^2$
c) $4x^2 - 24xy + 9y^2$
d) $9m^2 - 24mn + 16n^2$
- Factor each binomial.

a) $x^2 - 49$	b) $b^2 - 121$
c) $1 - q^2$	d) $36 - c^2$

B

- Factor each trinomial.

i) $a^2 + 10a + 25$	ii) $b^2 - 12b + 36$
iii) $c^2 + 14c + 49$	iv) $d^2 - 16d + 64$
v) $e^2 + 18e + 81$	vi) $f^2 - 20f + 100$
 - What patterns do you see in the trinomials and their factors in part a? Write the next 4 trinomials in the pattern and their factors.
- Factor each trinomial. Verify by multiplying the factors.

a) $4x^2 - 12x + 9$	b) $9 + 30n + 25n^2$
c) $81 - 36v + 4v^2$	d) $25 + 40h + 16h^2$
e) $9g^2 + 48g + 64$	f) $49r^2 - 28r + 4$

- Cut out a square from a piece of paper. Let x represent the side length of the square. Write an expression for the area of the square. Cut a smaller square from one corner. Let y represent the side length of the cut-out square. Write an expression for the area of the cut-out square.

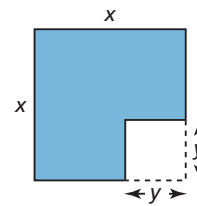

Write an expression for the area of the piece that remains.

- Cut the L-shaped piece into 2 congruent pieces, then arrange as shown below.

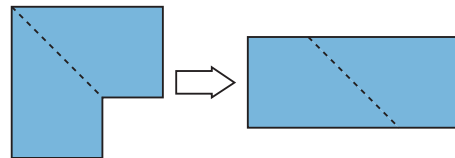

What are the dimensions of this rectangle, in terms of x and y ?

What is the area of this rectangle?

- Explain how the results of parts a and b illustrate the difference of squares.

10. Factor each binomial. Verify by multiplying the factors.

- a) $9d^2 - 16f^2$ b) $25s^2 - 64t^2$
 c) $144a^2 - 9b^2$ d) $121m^2 - n^2$
 e) $81k^2 - 49m^2$ f) $100y^2 - 81z^2$
 g) $v^2 - 36t^2$ h) $4j^2 - 225h^2$

11. Factor each trinomial.

- a) $y^2 + 7yz + 10z^2$ b) $4w^2 - 8wx - 21x^2$
 c) $12s^2 - 7su + u^2$ d) $3t^2 - 7tv + 4v^2$
 e) $10r^2 + 9rs - 9s^2$ f) $8p^2 + 18pq - 35q^2$

12. Factor each trinomial. Which trinomials are perfect squares?

- a) $4x^2 + 28xy + 49y^2$ b) $15m^2 + 7mn - 4n^2$
 c) $16r^2 + 8rt + t^2$ d) $9a^2 - 42ab + 49b^2$
 e) $12h^2 + 25hk + 12k^2$ f) $15f^2 - 31fg + 10g^2$

13. Factor.

- a) $8m^2 - 72n^2$ b) $8z^2 + 8yz + 2y^2$
 c) $12x^2 - 27y^2$ d) $8p^2 + 40pq + 50q^2$
 e) $-24u^2 - 6uv + 9v^2$ f) $-18b^2 + 128c^2$

14. A circular fountain has a radius of r centimetres. It is surrounded by a circular flower bed with radius R centimetres.

- a) Sketch and label a diagram.
 b) How can you use the difference of squares to determine an expression for the area of the flower bed?
 c) Use your expression from part b to calculate the area of the flower bed when $r = 150$ cm and $R = 350$ cm.

15. a) Find an integer to replace \square so that each trinomial is a perfect square.

- i) $x^2 + \square x + 49$
 ii) $4a^2 + 20ab + \square b^2$
 iii) $\square c^2 - 24cd + 16d^2$

b) How many integers are possible for each trinomial in part a? Explain why no more integers are possible.

16. Find consecutive integers a , b , and c so that the trinomial $ax^2 + bx + c$ can be factored. How many possibilities can you find?

17. Use mental math to determine $(199)(201)$. Explain your strategy.

18. Determine the area of the shaded region. Simplify your answer.

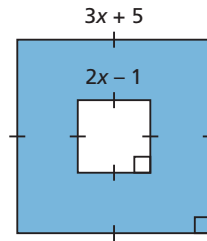

C

19. a) Identify each expression as a perfect square trinomial, a difference of squares, or neither. Justify your answers.

- i) $(x^2 + 5)^2$
 ii) $-100 + r^2$
 iii) $81a^2b^2 - 1$
 iv) $16s^4 + 8s^2 + 1$

b) Which expressions in part a can be factored? Factor each expression you identify.

20. Factor fully.

- a) $x^4 - 13x^2 + 36$
 b) $a^4 - 17a^2 + 16$
 c) $y^4 - 5y^2 + 4$

21. Factor, if possible. For each binomial that cannot be factored, explain why.

- a) $8d^2 - 32e^2$
 b) $25m^2 - \frac{1}{4}n^2$
 c) $18x^2y^2 - 50y^4$
 d) $25s^2 + 49t^2$
 e) $10a^2 - 7b^2$
 f) $\frac{x^2}{16} - \frac{y^2}{49}$

Reflect

Explain how a difference of squares binomial is a special case of a trinomial. How is factoring a difference of squares like factoring a trinomial? How is it different? Include examples in your explanation.

STUDY GUIDE

CONCEPT SUMMARY

Big Ideas

- Arithmetic operations on polynomials are based on the arithmetic operations on whole numbers, and have similar properties.
- Multiplying and factoring are inverse processes, and a rectangle diagram can be used to represent them.

Applying the Big Ideas

This means that:

- Factors and multiples can be found for both whole numbers and polynomials.
- We multiply factors to determine their product.
- For trinomials, the factors can be constant terms, monomials, binomials, or trinomials. When we multiply the factors, we expand.
- We factor a polynomial by writing it as a product of its factors.
- Algebra tiles or a rectangle diagram can represent a product of polynomials.

Reflect on the Chapter

- Describe how the operations of addition, subtraction, and multiplication on whole numbers are similar to these operations on polynomials. Include examples in your description.
- Explain how a rectangle diagram is used to multiply and factor whole numbers and to multiply and factor polynomials. Why can the rectangle diagram be used for both multiplying and factoring?

SKILLS SUMMARY

Skill	Description	Example
Determine prime factors, greatest common factor (GCF), and least common multiple (LCM). [3.1]	Express a whole number as the product of its prime factors, using powers where possible. Use the prime factors to determine GCF and LCM.	As a product of prime factors: $64 = 2^6$ and $80 = 2^4 \cdot 5$ The GCF of 64 and 80 is: $2^4 = 16$ The LCM of 64 and 60 is: $2^6 \cdot 5 = 320$
Determine whether a number is a perfect square or a perfect cube. [3.2]	Use prime factors to check for perfect squares and perfect cubes.	$4225 = 5^2 \cdot 13^2$ Since the factors occur in pairs, 4225 is a perfect square and $\sqrt{4225}$ is: $5 \cdot 13 = 65$ 4225 is not a perfect cube because the factors do not occur in sets of 3.
Determine common factors for a polynomial. [3.3]	Look at the terms and determine their greatest common factor. Multiply the factors to verify.	$3x^2y - 21xy + 30y^2$ $= 3y(x^2 - 7x + 10y)$
Multiply binomials of the form $(x + a)(x + b)$ and $(ax + b)(cx + d)$. [3.4, 3.5, 3.6]	Use algebra tiles, diagrams, and the distributive property to multiply.	$(3d + 2)(4d - 5)$ $= 12d^2 - 15d + 8d - 10$ $= 12d^2 - 7d - 10$
Factor polynomials of the form $x^2 + bx + c$ and $ax^2 + bx + c$. [3.4, 3.5, 3.6]	Use algebra tiles, diagrams, and symbols to factor. Look for common factors first. Multiply the factors to verify.	$5x^2 - 9x - 2$ $= 5x^2 - 10x + x - 2$ $= 5x(x - 2) + 1(x - 2)$ $= (x - 2)(5x + 1)$
Multiply polynomials. [3.7]	Use the distributive property to multiply each term in the first polynomial by each term in the second polynomial.	$(x - 4)(3x^3 + 5x - 2)$ $= 3x^4 + 5x^2 - 2x - 12x^3 - 20x + 8$ $= 3x^4 - 12x^3 + 5x^2 - 22x + 8$
Factor special polynomials. [3.8]	Factor a perfect square trinomial and a difference of squares binomial. Look for common factors first. Multiply the factors to verify.	$25x^2 - 49y^2$ $= (5x + 7y)(5x - 7y)$ $4x^2 + 16xy + 16y^2$ $= 4(x + 2y)(x + 2y)$

REVIEW

3.1

- Determine the prime factors of each number, then write the number as a product of its factors.
 - 594
 - 2100
 - 4875
 - 9009
- Determine the greatest common factor of each set of numbers.
 - 120, 160, 180
 - 245, 280, 385
 - 176, 320, 368
 - 484, 496, 884
- Determine the least common multiple of each set of numbers.
 - 70, 90, 140
 - 120, 130, 309
 - 200, 250, 500
 - 180, 240, 340
- A necklace has 3 strands of beads. Each strand begins and ends with a red bead. If a red bead occurs every 6th bead on one strand, every 4th bead on the second strand, and every 10th bead on the third strand, what is the least number of beads each strand can have?
- Simplify. How did you use the greatest common factor or the least common multiple?
 - $\frac{1015}{1305}$
 - $\frac{2475}{3825}$
 - $\frac{6656}{7680}$
 - $\frac{7}{36} + \frac{15}{64}$
 - $\frac{5}{9} \div \frac{3}{4}$
 - $\frac{28}{128} - \frac{12}{160}$

3.2

- How do you know that the area of each square is a perfect square? Determine the side length of each square.

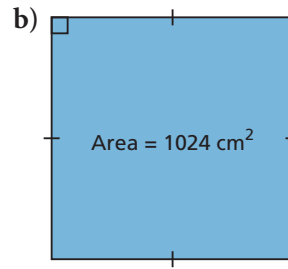
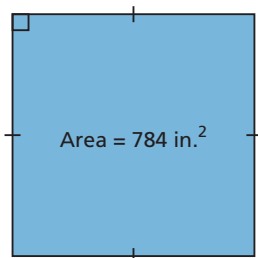

- How do you know that the volume of each cube is a perfect cube? Determine the edge length of each cube.

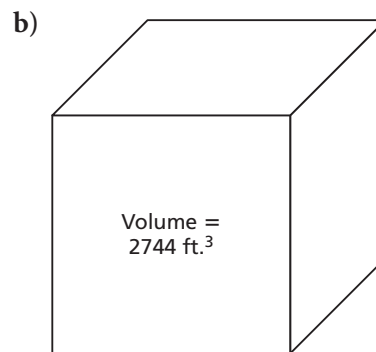
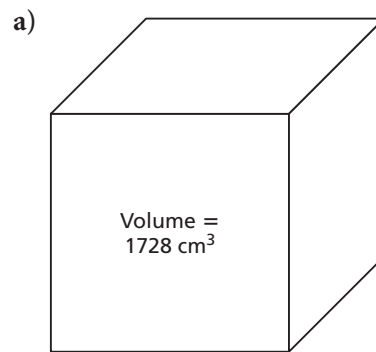

- Is each number a perfect square, a perfect cube, or neither? Determine the square root of each perfect square and the cube root of each perfect cube.
 - 256
 - 324
 - 729
 - 1298
 - 1936
 - 9261
- A square has area 18 225 square feet. What is the perimeter of the square?
- A cube has surface area 11 616 cm². What is the edge length of the cube?

3.3

11. Factor each binomial. For which binomials could you use algebra tiles to factor? Explain why you could not use algebra tiles to factor the other binomials.

- a) $8m - 4m^2$
 b) $-3 + 9g^2$
 c) $28a^2 - 7a^3$
 d) $6a^2b^3c - 15a^2b^2c^2$
 e) $-24m^2n - 6mn^2$
 f) $14b^3c^2 - 21a^3b^2$

12. Factor each trinomial. Verify that the factors are correct.

- a) $12 + 6g - 3g^2$
 b) $3c^2d - 10cd - 2d$
 c) $8mn^2 - 12mn - 16m^2n$
 d) $y^4 - 12y^2 + 24y$
 e) $30x^2y - 20x^2y^2 + 10x^3y^2$
 f) $-8b^3 + 20b^2 - 4b$

13. Factor each polynomial. Verify that the factors are correct.

- a) $8x^2 - 12x$
 b) $3y^3 - 12y^2 + 15y$
 c) $4b^3 - 2b - 6b^2$
 d) $6m^3 - 12m - 24m^2$

14. Find and correct the errors in each factorization.

- a) $15p^2q + 25pq^2 - 35q^3$
 $= 5(3p^2q + 5pq^2 - 7q^3)$
 b) $-12mn + 15m^2 + 18n^2$
 $= -3(-4mn + 15m^2 + 18n^2)$

3.4

15. Use algebra tiles. Sketch the tiles for each trinomial that can be arranged as a rectangle.

- a) $x^2 + 8x + 12$ b) $x^2 + 7x + 10$
 c) $x^2 + 4x + 1$ d) $x^2 + 8x + 15$

16. Use algebra tiles. Sketch the tiles for each trinomial that can be arranged as a rectangle.

- a) $2k^2 + 3k + 2$ b) $3g^2 + 4g + 1$
 c) $2t^2 + 7t + 6$ d) $7h^2 + 5h + 1$

17. Suppose you have one x^2 -tile and five 1-tiles. What is the fewest number of x -tiles you need to arrange the tiles in a rectangle?

3.5

18. Expand and simplify. Sketch a rectangle diagram to illustrate each product.

- a) $(g + 5)(g - 4)$ b) $(h + 7)(h + 7)$
 c) $(k - 4)(k + 11)$ d) $(9 + s)(9 - s)$
 e) $(12 - t)(12 - t)$ f) $(7 + r)(6 - r)$
 g) $(y - 3)(y - 11)$ h) $(x - 5)(x + 5)$

19. Factor. Check by expanding.

- a) $q^2 + 6q + 8$ b) $n^2 - 4n - 45$
 c) $54 - 15s + s^2$ d) $k^2 - 9k - 90$
 e) $x^2 - x - 20$ f) $12 - 7y + y^2$

20. a) Factor each trinomial.

- i) $m^2 + 7m + 12$
 ii) $m^2 + 8m + 12$
 iii) $m^2 + 13m + 12$
 iv) $m^2 - 7m + 12$
 v) $m^2 - 8m + 12$
 vi) $m^2 - 13m + 12$

b) Look at the trinomials and their factors in part a. Are there any other trinomials that begin with m^2 , end with $+12$, and can be factored? If your answer is yes, list the trinomials and their factors. If your answer is no, explain why there are no more trinomials.

21. Find and correct the errors in each factorization.

- a) $u^2 - 12u + 27 = (u + 3)(u + 9)$
 b) $v^2 - v - 20 = (v - 4)(v + 5)$
 c) $w^2 + 10w - 24 = (w + 4)(w + 6)$

3.6

22. Use algebra tiles to determine each product. Sketch the tiles to show how you used them.

- a) $(h + 4)(2h + 2)$ b) $(j + 5)(3j + 1)$
 c) $(3k + 2)(2k + 1)$ d) $(4m + 1)(2m + 3)$

- 23.** For each set of algebra tiles below:
- Write the trinomial that the algebra tiles represent.
 - Arrange the tiles to form a rectangle. Sketch the tiles.
 - Use the rectangle to factor the trinomial.

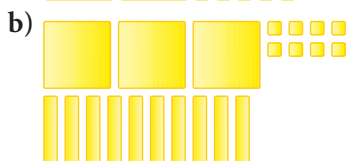

- 24.** Expand and simplify. Sketch a rectangle diagram to illustrate each product.
- $(2r + 7)(3r + 5)$
 - $(9y + 1)(y - 9)$
 - $(2a - 7)(2a - 6)$
 - $(3w - 2)(3w - 1)$
 - $(4p + 5)(4p + 5)$
 - $(-y + 1)(-3y - 1)$

- 25.** Factor. Check by expanding.
- $4k^2 - 7k + 3$
 - $6c^2 - 13c - 5$
 - $4b^2 - 5b - 6$
 - $6a^2 - 31a + 5$
 - $28x^2 + 9x - 4$
 - $21x^2 + 8x - 4$

- 26.** Find and correct the errors in each factorization.
- $6m^2 + 5m - 21 = (6m - 20)(m + 1)$
 - $12n^2 - 17n - 5 = (4n - 1)(3n + 5)$
 - $20p^2 - 9p - 20 = (4p + 4)(5p - 5)$

3.7

- 27.** Expand and simplify. Check the product by substituting a number for the variable.

- $(c + 1)(c^2 + 3c + 2)$
- $(5 - 4r)(6 + 3r - 2r^2)$
- $(-j^2 + 3j + 1)(2j + 11)$
- $(3x^2 + 7x + 2)(2x - 3)$

- 28.** Expand and simplify.

- $(4m - p)^2$
- $(3g - 4h)^2$
- $(y - 2z)(y + z - 2)$
- $(3c - 4d)(7 - 6c + 5d)$

- 29.** Expand and simplify. Check the product by substituting a number for the variable.

- $(m^2 + 3m + 2)(2m^2 + m + 5)$
- $(1 - 3x + 2x^2)(5 + 4x - x^2)$
- $(-2k^2 + 7k + 6)(3k^2 - 2k - 3)$
- $(-3 - 5h + 2h^2)(-1 + h + h^2)$

- 30.** Expand and simplify.

- $(5a + 1)(4a + 2) + (a - 5)(2a - 1)$
- $(6c - 2)(4c + 2) - (c + 7)^2$

- 31.** Suppose n represents an even integer.

- Write an expression for each of the next two consecutive even integers.
- Write an expression for the product of the 3 integers. Simplify the expression.

3.8

- 32.** Factor.

- $81 - 4b^2$
- $16v^2 - 49$
- $64g^2 - 16h^2$
- $18m^2 - 2n^2$

- 33.** Factor each trinomial. Check by multiplying the factors.

- $m^2 - 14m + 49$
- $n^2 + 10n + 25$
- $4p^2 + 12p + 9$
- $16 - 40q + 25q^2$
- $4r^2 + 28r + 49$
- $36 - 132s + 121s^2$

- 34.** Factor each trinomial. Which strategy did you use each time?

- $g^2 + 6gh + 9h^2$
- $16j^2 - 24jk + 9k^2$
- $25t^2 + 20tu + 4u^2$
- $9v^2 - 48vw + 64w^2$

- 35.** Determine the area of the shaded region. Write your answer in simplest form.

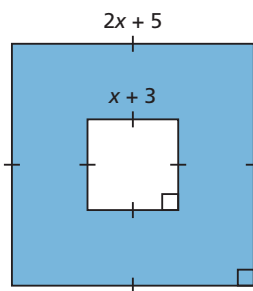

PRACTICE TEST

For questions 1 and 2, choose the correct answer: A, B, C, or D

- For the number 64, which statement is not true?
 - It has only one factor.
 - It is a perfect square.
 - It is a perfect cube.
 - Its prime factor is 2.
- The factorization of the trinomial $2x^2 + 7x + 6$ is:
 - $(2x + 1)(x + 6)$
 - $(2x + 2)(x + 3)$
 - $(2x + 3)(x + 2)$
 - $(2x + 6)(x + 1)$
- Write each number below as a product of its prime factors, then determine the least common multiple and the greatest common factor of the 3 numbers.
20 45 50
- Look at the numbers in question 3.
 - What would you have to multiply each number by to produce a number that is:
 - a perfect square?
 - a perfect cube?
 - Why is there more than one answer for each of part a?
- Expand and simplify, using the strategy indicated. Sketch a diagram to illustrate each strategy.
 - Use algebra tiles: $(2c + 5)(3c + 2)$
 - Use an area model: $(9 + 4r)(8 + 6r)$
 - Use a rectangle diagram: $(4t - 5)(3t + 7)$
- Expand and simplify.
 - $(2p - 1)(p^2 + 2p - 7)$
 - $(e + 2f)(2f^2 + 5f + 3e^2)$
 - $(3y + 2z)(y + 4z) - (5y - 3z)(2y - 8z)$
- Factor each polynomial. For which trinomials could you use algebra tiles? Explain.
 - $f^2 + 17f + 16$
 - $c^2 - 13c + 22$
 - $4t^2 + 9t - 28$
 - $4r^2 + 20rs + 25s^2$
 - $6x^2 - 17xy + 5y^2$
 - $h^2 - 25j^2$
- A cube has edge length $2r + 1$. A right square prism with dimensions r by r by $2r + 1$ is removed from the cube.
Write an expression for the volume that remains. Simplify the expression.
- Write all the trinomials that begin with $8t^2$, end with $+3$, and can be factored.
How do you know you have found all the trinomials?